

Weather Resistant Power Box

VSBKTA6400S

Technical Specifications

Weather resistant power box accommodates many types of electrical components such as power adapters, air circuit breakers, and lighting surge protectors

Model	VSBKTA6400S
Materials	Aluminium alloy/ SECC steel
Load Bearing Capacity	8.0kg
Pipe Thread	Refer diagram
Operating Conditions	-40°C to +60°C less than 90% (RH)
Weather Resistance	IP66 rated
Dimensions	297.2mm x 248.0mm x 130.7mm
Weight	3.38kg



Product specifications and bracket compatibility are subject to change.

Product Diagrams & Dimensions

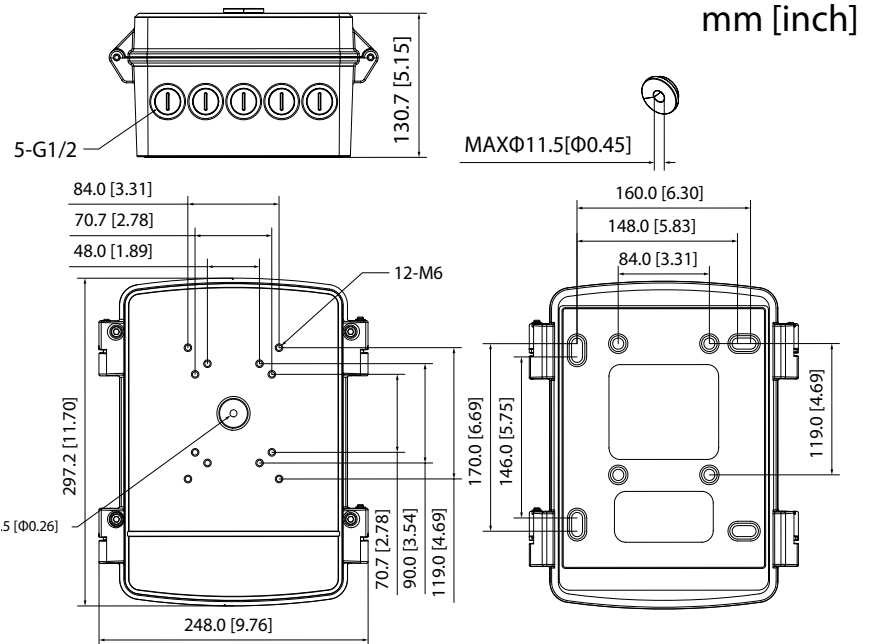
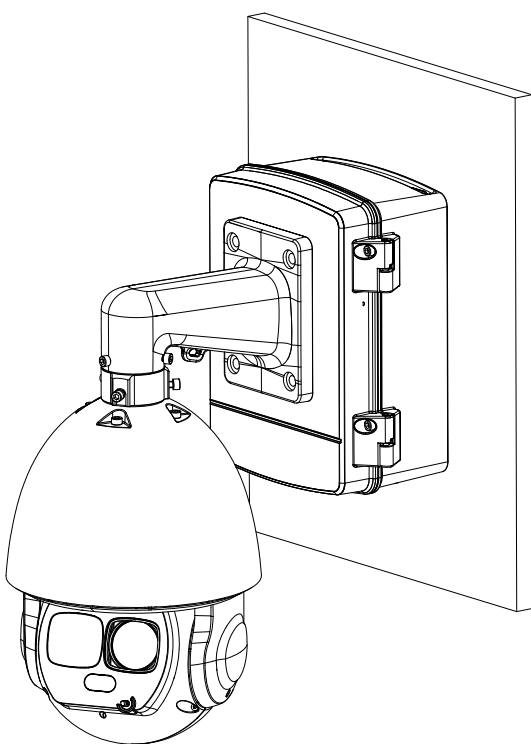

Your professional CCTV surveillance dealer: