

Outdoor Power/Comms Box

Model: VSBKTA6401S

Technical Specifications

Aluminum weather resistant power box, easy to install, supports a variety of installation methods such as wall & pole mount and ideal for mounting cameras.

Model	VSBKTA6401S
Materials	Aluminium
Load Bearing Capacity	8.00kg
Operating Conditions	-40° ~ 60°C / 90% RH (max)
Weather Resistance	IP66 rated
Dimensions	297 x 248 x 131mm
Weight	3.33kg



Product specifications and bracket compatibility are subject to change.

Product Diagrams & Dimensions

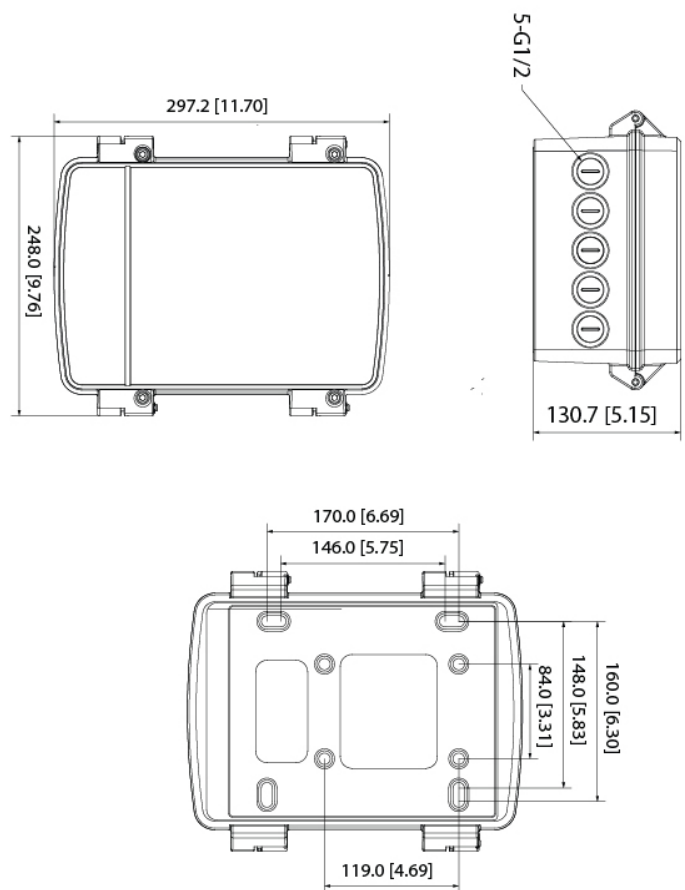
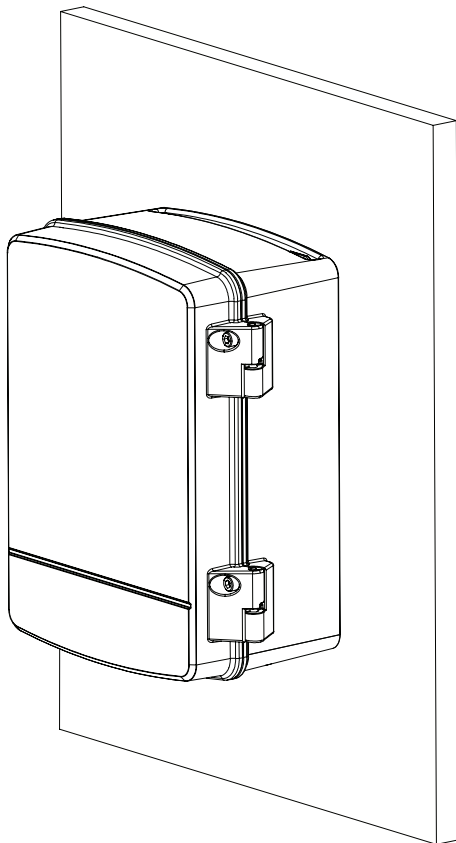

Your professional CCTV surveillance dealer: