



Africa's leading manufacturer and distributor of electronic security products.

XSeries Serial Installer Manual

1. Keypads	4
Keypad Indicator Icons	6
Button Details	6
2. Introduction to the IDS X-Series	7
Features of the IDS X-Series	7
3. Installation and Wiring	8
Installation Requirements	9
End-of-Line Resistors	9
Box Tamper Input	9
Connecting the DTMF Communicator - Advanced	9
Programmable Outputs	9
Key-Switch or Remote Control Unit	9
Installing Expander Modules	9
IDS Remote Receiver	9
Transmitter Connection	9
Hardware Default Switch	10
Enrolling Keypads and Other Bus-wired Peripherals	10
Replacing a Damaged Keypad/Bus-wired Peripheral	10
Defaulting Keypads	11
4. Event Log	11
Normal User Code	11
Master User Code	11
Maid's Code (Arm to Disarm Code)	11
Duress Code	11
Installer Code	11
Maintenance Code	12
Download Code	12
5. How to Read Location Values	12
6. Programming of the Panel	13
7. Programming Quick Reference Guide	14
8. Programming Location Summary	15
Zones	15
Global Setup	18
Daylight Savings	22
Miscellaneous– Advanced	23
DTMF Phone Numbers	25
Zone Properties	26
No Movement– Advanced	27
Security Codes	29
Partition Options	29
Delays	31
Options to Configure Keypads	31
Wireless Integration Options	33
Zone Reporting Codes	33
Programmable Outputs	34
Output Disarm Clear	35
Partition Event Driven Outputs– Advanced	36
Zone Programmable Output Events	37
Output Pulse Timing - Advanced	38
Output Scheduling On Time - Advanced	38
Output Scheduling Off Time - Advanced	39
Output Scheduling On/Off Days - Advanced	39
Enable or Disable of Event Reporting Options - Advanced	40
9. Touch Keypad Switch to Programmable Output Mapping	42
10. Xwave² Outputs	42
11. LCD Keypad Information	42
12. Panel Information	43
13. User Options	43
14. Appendix	44
15. Trouble Display	46

CURVE LCD KEYPAD

POWER INDICATOR (RED)
This indicator is illuminated when mains power is present.

ARMED INDICATOR (RED)
The indicator is illuminated when the system is armed.

MODE KEY
Used to switch between partitions and toggle between upper and lower case.

MEDICAL ALARM
This key will activate the MEDICAL ALARM when held down for one second.

FIRE ALARM
This key will activate the FIRE ALARM when held down for one second.

PANIC ALARM
This key will activate the PANIC ALARM when held down for one second.

STAR KEY
Used to select and de-select, or when held down for 2 seconds, to enter the Main Menu.

HASH KEY
A Cancel or Exit key.



CURVE LED KEYPAD

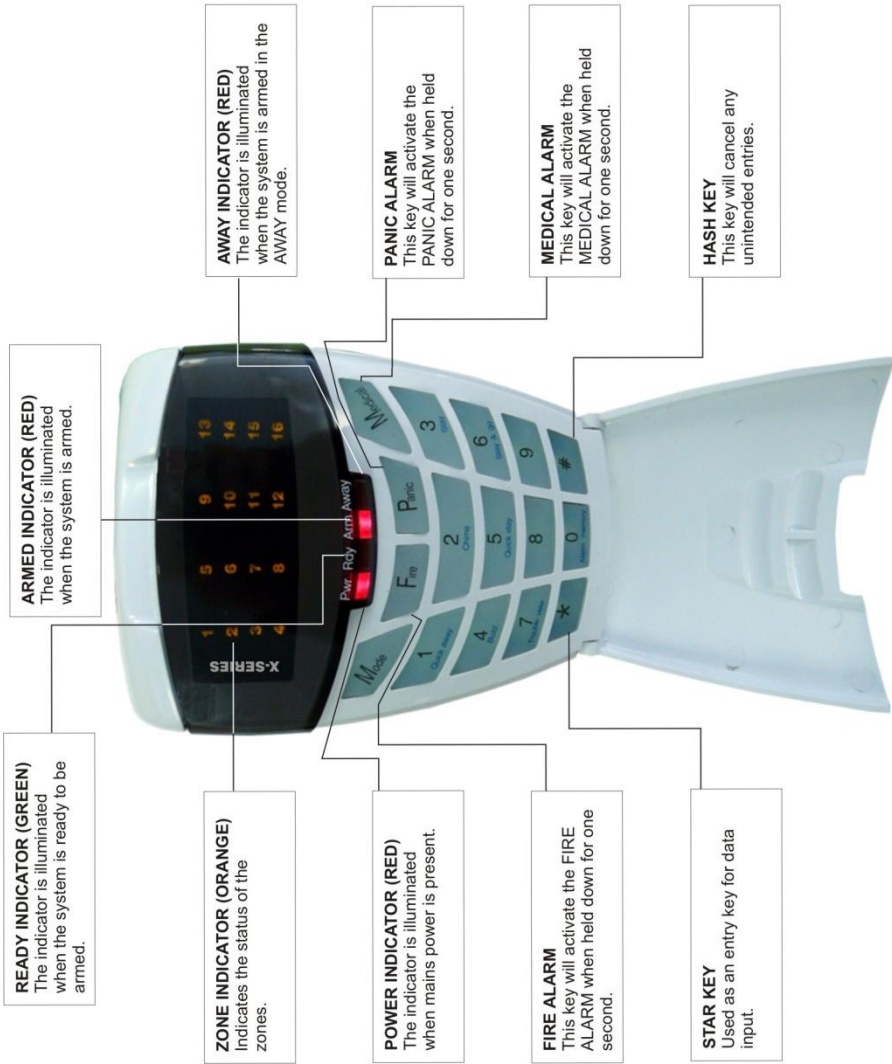

New LCD KEYPAD

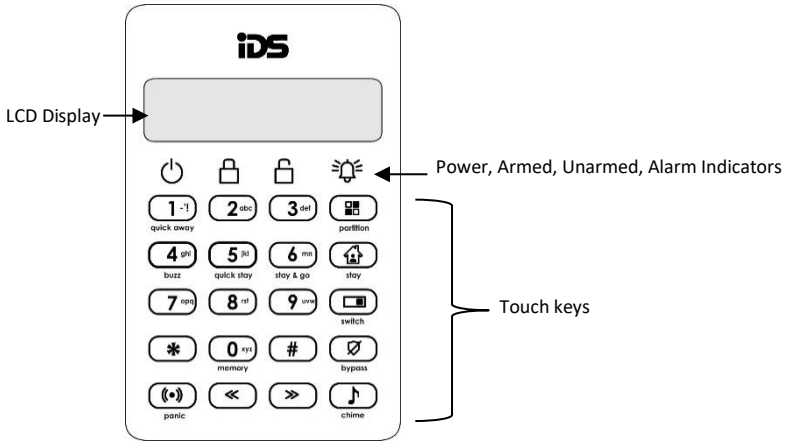

Keypad Indicator Icons

Power indicator icon has two functions:



1. When the icon is on, this indicates the keypad is powered up.
2. Flashing indicates an issue has occurred and needs your attention.



Armed icon indicates the system is armed either in 'away' or 'stay' mode. The LCD will display the armed mode.



Unarmed icon will be illuminated when the system is not armed.



Alarm icon will flash when an alarm condition has occurred.

Button Details



partition

Partition Button is to select a partition that you would like to interact with via the keypad.

NOTE: Only available if the keypad is configured as a global keypad!



stay

Stay Button allows you to select which stay profile to stay arm the system with.

NOTE: Only available if more than one stay profile has been programmed. (see X-Series user manual)



switch

Switch Button allows access to outputs that could be used to switch devices, lights on/off or open/close gates, etc. (Function not currently implemented)



bypass

Bypass button allows you to disable zones so that they cannot violate the alarm.



chime

Chime button selects which zones, will cause the keypad to chime when violated while the system is disarmed.



left

Navigation buttons allows you to scroll through menus, and when editing zone names, etc. Press and hold left arrow buttons to change the keypad sounds.



right



panic

Panic button when held down for 3 seconds will sound the siren and send a panic signal to the security company if the alarm is configured to do so.

2. Introduction to the IDS X-Series

Thank you for purchasing an IDS Alarm Panel.

The IDS XSeries alarm is a versatile, Bylaw 25 compliant, expandable Alarm Panel. It comes in two versions, X16s and X64s. Both have up to 8 partitions and can have up to 8 keypads. The X16s can be expanded from 8 to 16 zone, the X64s from 8 to 64 zones. Most features are configurable and may be programmed directly through a keypad or via serial PC connection, using the IDSwift 2 Download Software and appropriate USB Panel Interface device (P/N: 860-320-01).

There are up to 64 programmable burglary zones on the X64S and 16 programmable burglary zones on the X16S. A dedicated panic zone monitored, siren output, auxiliary power output, and 5 onboard programmable outputs expandable to 41 outputs.

For correct operation the IDS XSeries panels must be used in conjunction with the specified transformer/battery combination (ask your sales representative for a copy of the IDS Power Budget spreadsheet to identify your needs) and appropriate peripheral sensors and signalling devices.

NOTE: XSERIES products are not compatible with any previous IDS products, such as the IDS816 and IDS1632.

Features of the IDS X-Series

Zones and Partitions:

- 8 onboard zones, expandable to 16 onboard zones with a XSeries 8-zone Plug-in Expander (P/N: 860-06-X-08PI) –A very cost-effective 16 zone solution
- Further expandable to 64 zones with the use of up to 6 bus-wired X64S 8-zone Unpowered Expander modules (P/N: 860-06-X-08S) or 8 keypad zones - 1 per keypad
- All zones can be expanded with wireless receivers to receive signals from the Xwave & Xwave² range of enabled wireless detectors. All wireless zones are fully supervised
- The system can also have a hybrid of wired and wireless zones totalling 64 zones for the X64S and 16 zones for the X16S
- 8 partitions
- 4 stay profiles per partition

Users:

- 128 users
- Options to set user codes as Master, Duress, Maid, Arm only, Disarm only or Output Trigger.

System Options:

- Tamper reporting per zone using double end-of-line resistors (12K and 4K7)
- 5 programmable outputs on the Alarm Panel, expandable to 41 when using zone expanders (2 per expander), keypads (1 per keypad) and output expanders (8 per expander)
- Event log (1000 events) date and time relative
- Auto arm/disarm capability per partition and by day of the week.
- No movement auto arm and medical reporting
- Panel firmware installer upgradable via serial data cable
- Comprehensive lightning protection
- Dynamic battery self-test
- Low battery monitoring and cut-out circuit
- Switch mode power supply, with an independent battery charging circuit, means more onboard power for simplified alarm installation
- 2 x 8 channel output expander support.

3. Installation and Wiring

*The kick start jumper must be in-circuit when using only a battery (i.e. no Mains). Simply short the pins out with a screwdriver or use a jumper. Remove the short/jumper once the Panel Status LED lights up (indicating power up), as leaving it on disables the low battery cut-out. *

Figure 1: Connection Diagram

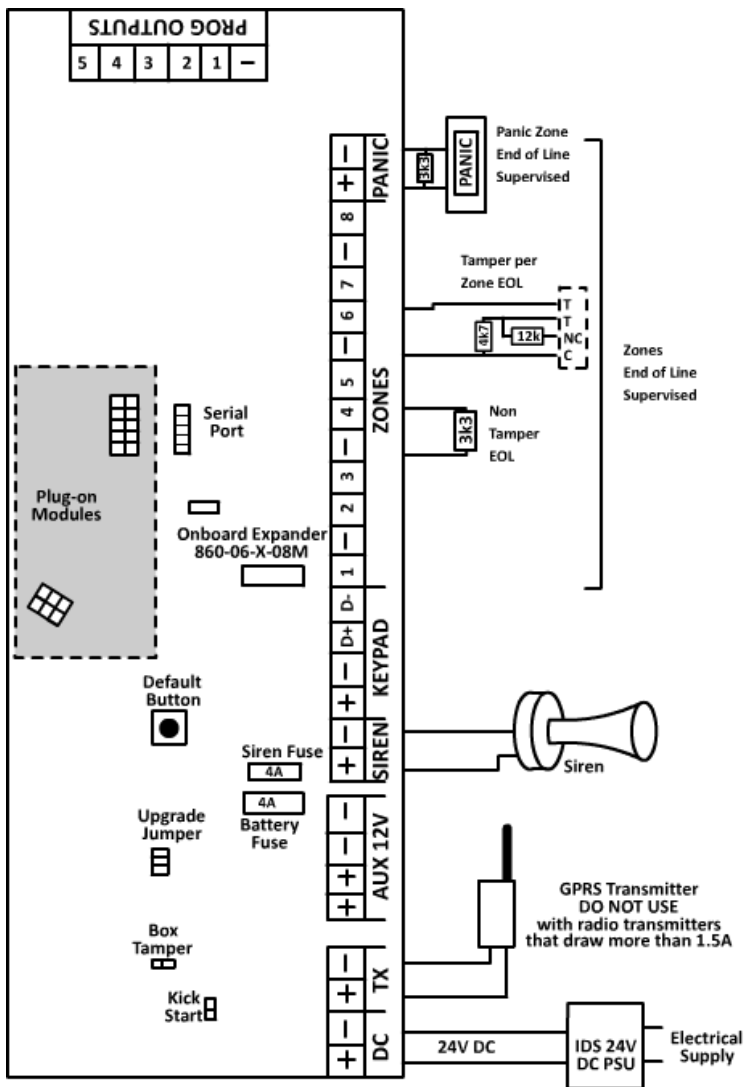

Note: When using extra power supplies to power any peripheral connected to the keypad bus an IDS RS485 isolator (860-06-0557) must be used.

Installation Requirements

An IDS 24V 1.5A DC power supply (861-632).

A 12V sealed lead acid battery with a capacity of 7AH must be used. The backup period after mains failure will depend on the number of keypads, sensors, and bus-wired peripheral devices connected to the system.

Connect a 12V self-driven siren or piezo siren (not a horn speaker) to the siren output.

The panel can supply a total continuous current of 1A to bus-wired peripheral devices such as keypads, remotes, receivers, passives etc.; from Aux 12V terminals.

End-of-Line Resistors

- All zones, including Panic zones, are end-of-line supervised.
- All zones, whether they are used or unused, need to be terminated with a 3K3 resistor (resistor colour-code is orange, orange, red, gold).
- For maximum security, the end-of-line resistor must be placed inside or as close to the sensor as possible.
- For tamper by zone, 4K7 and 12K end-of-line resistors must be connected instead of a single 3K3 resistor.
- If the panel is unarmed and a tamper condition occurs, the siren will not sound but a tamper condition will be reported if it is enabled to do so. See Table 37 to enable/disable this option.
- If the panel is armed and a tamper condition occurs, an audible alarm will register, and a tamper condition AND zone violation will be reported.

Box Tamper Input

The box tamper input does not require an end-of-line resistor, but does require a normally closed contact. The panel is shipped with the box tamper input bypassed. To use it, remove the jumper and connect a normally closed contact onto the terminals. Refer to Figure 1: Connection Diagram. (Box tamper kit 861-020)

Connecting the DTMF Communicator - Advanced

A separate DTMF module is available (860-06-658) for communication to DTMF communicators.

Note: Do not connect to any type of telephone line.

Programmable Outputs

A relay must be used when any device requiring a current greater than 100mA is connected to an onboard programmable output. The onboard programmable output circuitry is a current sink circuit with a maximum output voltage of 13.6Vdc and a maximum output current of 100mA. Programmable outputs are primarily connected for radio transmitter. The output expander, part no. 860-06-0596, has eight 1-amp DC relays to be able to manage a higher current to be used for connecting, LEDs, sirens, bus-wired peripherals, etc.

Key-Switch or Remote Control Unit

A key-switch, (not recommended) or non-IDS remote receiver maybe connected to any zone to allow remote arm/disarm and remote panic capability.

- When using a key-switch or remote control unit, a 3K3 resistor must be connected between the zone input and ground.
- Use only a spring-loaded momentary key-switch or non-latching remote-control unit.

Installing Expander Modules

When installing expander modules please refer to the document supplied with the module. Note that up to 6 bus-wired, 8-zone expander modules (P/N: 860-06-X-08S), 1 plug-in expander (P/N: 860-06-X-08PI) and 2 bus-wired output expanders may be added to the IDS X64 Alarm Panel. Zones 9-16 are reserved for the Plug-in Zone Expander module which may be used on the X16 as well.

IDS Remote Receiver

Up to 4 IDS Remote Receivers (P/N: 860-07-X02-DI) may be connected to the keypad bus. Using this facility allows remote arming and disarming of the panel while providing user identification for a maximum of 128 remotes. For a full list of features and benefits of the receiver, please see the manual that comes with it.

Transmitter Connection

When connecting a GSM transmitter, use the TX terminal provided on the panel to supply power to the transmitter. This output is protected by a 4 Amp fuse. This will also help protect the battery by cutting power to it to stop it from being drained.

Note: Do not use with high power transmitters that draw more than 1.5Amps.

Hardware Default Switch

Use the hardware default switch (refer to Figure 1) to return the panel to its factory default settings.

The procedure to default the panel is as follows:

1. Remove the battery and Mains power from the panel
2. If you are only using a battery, make sure that the kick-start jumper is in circuit
3. Hold down the default switch and reapply power to the panel (battery or Mains)
4. Wait for the Panel Status LED to flash
5. Release the default switch
6. Remove the kick-start jumper, if one was used
7. Defaulting is complete once the Panel Status LED starts flashing

The effects of applying the default:

1. Factory default values are restored to all locations
2. All attached keypad IDs are defaulted
3. The event log is not cleared
4. The “system default” event is logged to the event log

NOTE: The hardware default switch can be disabled in location 35.

See also: Defaulting the Panel or Master User Code – location 0 Enrolling Keypads and Other Bus-wired Peripherals

Enrolling Keypads and Other Bus-wired Peripherals

Keypads must be enrolled on the system before they can be used. Keypads are allocated an ID in the order in which they are enrolled. To enrol a keypad:

1. Wire all keypads to the bus
2. Power the system up
3. Press the [#]key in the order required

The first keypad enrolled will have an ID of 1, the second enrolled will have an ID of 2, the third an ID of 3 etc.

NOTE:

- All the zone and LEDs will flash on a keypad that does not have an ID.
- The POWER and READY LEDs will be on for a keypad that has an ID and no zone violations.
- Only the POWER LED will be on for a keypad that has an ID with a zone violation. The LED for that zone will also flash.

Trouble shooting

If the ID process, for an LED keypad, has failed zones 1-8, and zones 9-16 will flash alternately. At this point press the [#] key to retry.

If the flashing persists, try the following steps:

1. Check all wiring
2. Check that you have not exceeded 8 keypads on the bus
3. Contact the IDS helpdesk for further support

NOTE: To enrol other devices (IDS Remote Receivers or Zone Expanders); consult the installation manuals for those devices. The IDS X64Alarm Panels can accept 6 zone expanders and 4 remote receivers.

Replacing a DamagedKeypad/Bus-wired Peripheral

To replace a damaged device (non-dipswitch – like a keypad):

1. Disconnect only the faulty device while the system is powered down.
2. Program a value of [4] into location 0 to free up all redundant IDs (previously unallocated IDs remain free), wait for approximately 30 seconds then continue to step 3.
3. Connect the replacement device and enrol it –by pressing [#] for keypads – it will now be enrolled in the first available address.

NOTE:

- If other devices are disconnected (or damaged), at the time of performing step 2, their addresses will also be freed. Any new devices being enrolled will automatically be allocated addresses beginning from the lowest free address.
- When you free up the ID of the damaged unit, the panel settings, relevant to the ID, will be defaulted too. Therefore, the keypad will need to be re-added to a partition.
- If a new keypad was enrolled, go to location 243 to check the keypad’s ID (1-8).

Defaulting Keypads

To default the ID of an individual LCD or LED keypad:

1. Remove power to the keypad (or the whole panel if easier).
2. Hold down the **[1]** and **[3]** keys simultaneously.
3. Restore the power.
4. Wait for three seconds and then release the keys (there will not be a beep).
5. All the keypad LEDs will flash simultaneously indicating that the keypad has been de-registered
4. Wait for five seconds and ensure that the Panel Status LED on the panel is flashing, if the panel power was removed.
5. Press the **[#]** key to allocate a new ID to the defaulted keypad. Keypad IDs are allocated incrementally.
6. The ID of any (correctly registered) keypad can be viewed in location 243 from the keypad of interest.

To default the ID of an individual Touch keypad:

1. Remove power from the keypad.
2. Switch all four dip switches to the ON position.
3. Power up the keypad for five seconds and then remove power.
4. Switch all four dip switches to the OFF position.
5. The keypad is defaulted and will be required to be registered when installed onto the alarm system.

To default the ID of ALL keypads:

1. Enter a value of **[3]** into location 0. **[INSTALLER CODE] [*] [0] [*] [3] [*]**
2. On pressing the final **[*]**, wait a few seconds and ALL the keypad LEDs will begin flashing. (Do NOT press the **[#]** key at the end of this sequence, unless you wish the keypad you are using to be registered in the first address).
3. Re-enrol all keypads by pressing the **[#]** key on each keypad – in the CORRECT sequence to ensure that keypad zone and partition allocation is as required by the user.

4. Event Log

A comprehensive log of the 1 000 most recent events is retained in the non-volatile EEPROM. The log may be retrieved using the up/download software, or on the LCD keypad. (See the LCD Keypad or User Manual to see how to view the event log).

IDSwt2 software is available for account customers, to download event logs via direct serial download.

Access Codes

The panel supports up to 128 users. The user codes can have various properties assigned to them. These properties allow the user codes to have different functions.

Normal User Code

A normal user code is used to arm/disarm the panel, and to access certain user options.

Master User Code

When assigned to a user, this property allows the user to act as a master user. The Master User Code has full access to programming all the user options. For a full list of user programmable options, refer to the XSeries Owner's Manual.

Maid's Code (Arm to Disarm Code)

This property may be used to limit access to the premises. A Maid's Code will only disarm the system if the same code was used for arming. If armed with a code other than this code, the system will view an attempt to disarm using a Maid's Code as an invalid entry. Any valid user code will disarm the system if it has been armed with a Maid's Code.

Duress Code

This property denotes a user code as a special code to be used in the unique situation where an intruder forces one to disarm the system "under duress".

When the **[DURESS CODE]** is entered, the Alarm Panel disarms normally - however a DURESS REPORTING CODE is transmitted to the monitoring company to inform them that you have been forced to disarm the Alarm Panel by an intruder. It is advisable to choose a code that can easily be remembered by all family (or staff) members.

Installer Code

The Installer Code (location 197) is used by the installer to program and configure the Alarm Panel. It has full access to all installer mode menus as listed in this manual.

Maintenance Code

The Maintenance Code (location 199) acts in a similar way to the Installer Code, but it has limited access to installer menus. The default Maintenance Code is 8888, or 888888 for a 6-digit code. This code is used to access the following locations:

Locations 17 - 18	Siren Time & Delay	Locations 20 – 22	Keypad Lockout and Sleep
Locations 25 – 31	Daylight Savings	Locations 171 – 173	No Movement, Auto Arm
Locations 174 – 176	No Movement, Medical Alarm	Locations 180 – 190	Auto Arm Times

The assignment of this property to a user allows the relevant user to perform certain “maintenance” tasks that would ordinarily require the use of the installer code.

Download Code

The Download Code, location 198, (in conjunction with the Installer Code) is required for download access via the IDS Download Software. The default Download Code is 9999 or 999999 for a 6-digit code.

NOTE: It is possible to program [location 34](#) to either allow or disallow defaulting of the Download Code.

5. How to Read Location Values

Values within a data program location will be displayed by the zone LEDs in binary coded decimal format i.e. zone LEDs 1-4 indicate units (ones), and zone LEDs 5-8 indicate tens (tens), and so on.

To read a binary value on the keypad, add up the values represented by each lit LED as shown in Table 1

Table 1: Values Represented by each Zone LED

Zone LED	Value	Digit	Zone LED	Value	Digit
Zone 1	1	Units	Zone 9	1	Hundreds
Zone 2	2		Zone 10	2	
Zone 3	4		Zone 11	4	
Zone 4	8		Zone 12	8	
Zone 5	1	Tens	Zone 13	1	Thousands
Zone 6	2		Zone 14	2	
Zone 7	4		Zone 15	4	
Zone 8	8		Zone 16	8	

EXAMPLE:

Imagine the following zone LEDs are on: Zone 1, Zone 3 and Zone 5.

Units are represented by the sum of Zone 1 and Zone 3 (i.e. 1 + 4).

Tens of units are represented by the value of Zone 5 (i.e. 1 x ten).

Therefore, the displayed value is (1+4) + (10) = 15.

Values within a time program location are displayed in a similar format as per Table 2.

Table 2: Binary Coded Decimal Four Digit Display

Zone LED	Calculation	Unit	Zone LED	Calculation	Unit
1	(x 1 = 1)	M	9	(x 1 = 1)	S
2	(x 2 = 0)		10	(x 2 = 2)	
3	(x 4 = 4)		11	(x 4 = 4)	
4	(x 8 = 0)		12	(x 8 = 0)	
5	(x 1 = 1)	m	13	(x 1 = 1)	s
6	(x 2 = 0)		14	(x 2 = 2)	
7	(x 4 = 4)		15	(x 4 = 1)	
8	(x 8 = 0)		16	(x 8 = 0)	

Mm:Ss
= 45:36

M = LEDs 4 through 1
m = LEDs 5 through 8
S = LEDs 12 through 9
s = LEDs 16 through 13

Using an LCD keypad means that data and time information can be read directly without a need to convert.

6. Programming of the Panel

The XSeries control panels is optimised to be programmed and used with an LCD keypad. The system can be programmed with an LED keypad except for a few locations which will be highlighted when such locations are discussed. The following section describes how programming data is represented in the XSeries panels and how to program it, specifically with the LED keypad.

For all programming procedures, the [*] key functions as the <ENTER> key and the [#] hash key functions as a <CLEAR> or an <EXIT> program key.

Invalid data entries are indicated by means of an error beep consisting of 3 short beeps of the keypad buzzer.

There are two location categories:

- > Standard locations which are single tiered and do not contain any sub-locations.
- > Extended locations, which are double tiered and have strings or sub-locations depending on programming preference.

Both standard and extended locations may contain further sub-categories referred to as bitmapped locations.

For both main categories, clear visual keypad prompts are provided, which aid the programming process.

NOTE: When you use the [*] key to scroll through a bitmapped location, it will scroll through the pages.

When using the [*] key to scroll through numbered locations, it will scroll through the bytes.

- > Alpha-numeric locations (location 51 - DTMF number), will show 1 digit per press of the [*] key.
- > Numeric locations (location 197 – installers code), will show 2 digits per press of the [*] key.
- > To view how the data is represented, please see Table 1.

Where a hexadecimal number must be programmed, use the [MODE] key as per Table 3.

Table 3: Hexadecimal Values

Hex Value	Decimal Value	Keystrokes
A	10	[MODE] key then [0] key
B	11	[MODE] key then [1] key
C	12	[MODE] key then [2] key

Hex Value	Decimal Value	Keystrokes
D	13	[MODE] key then [3] key
E	14	[MODE] key then [4] key
F	15	[MODE] key then [5] key

NOTE: The hex values of A-F can be used for account codes. Only B-F can be used for phone numbers. This means that for locations 50-54, A is NOT a hex number – but is rather used to CLEAR a DTMF number.

Entering Program Mode

- **[#] [INSTALLER CODE] [*]** to enter program mode.
- A long beep will confirm entry.
- The READY LED will flash.

Programming Standard Locations

- The panel is in program mode – the READY LED is flashing.
- **[LOCATION NUMBER] [*]**
- The READY LED is solid on, and the AWAY LED will flash.
- Either **[NEW DATA] [*]** or **[#]** to exit.
- If data is entered, a long beep will confirm entry.
- In both instances, the READY LED will to flash and the AWAY LED will turn off.
- **[#]** to exit the READY LED will stop flashing.
- The panel is now in standby mode.

Programming Extended Locations with Strings

- Panel is in program mode – the READY LED is flashing.
- **[LOCATION NUMBER] [*]**
- The READY LED is solid on, and the ARM and AWAYLEDs will flash.
- **[STRING][*]**
- The ARM and AWAY LEDs turn off, and the READY LED will flash.
- If you do not want to change data press **[#]**.
- The READY LED will continue to flash, whilst the ARM and AWAY LEDs turn off.
- **[#]** to exit the READY LED will stop flashing.
- The panel is now in standby mode.

Programming Extended Locations with Sub-locations

- Panel is in program mode – the READY LED is flashing.
- **[LOCATION NUMBER] [*]**
- The READY LED is solid on, and the ARM and AWAYLEDs will flash.
- **[SUB-LOCATION NUMBER] [*]**
- The READY and ARM are solid on, and AWAY is flashing.
- **[NEW DATA] [*]**
- The READY LED is solid on, and the ARM and AWAY LEDs will flash.
- **[#]** if you do not wish to make changes.
- The READY is flashing, and the ARM and AWAY LEDs turn off.
- **[#]** to exit current location.
- The READY is flashing, and the ARM and AWAY LEDs turn off.
- **[#]** to exit and the READY LED will stop flashing.
- The panel is now in standby mode.

Programming a Bitmapped Location

- Panel is in program mode – the READY LED is flashing.
- **[LOCATION NUMBER] [*]**
- The READY LED is solid, and the AWAY LED flashes.
- **[#]** to exit current location.
- READY is flashing.
- **[#]** to exit and the READY LED will stop flashing.
- The panel is now in standby mode.

For a more detailed programming explanation, please see the XSeries training manuals

8. Programming Location Summary

A detailed description of each location and its options follow.

LOCATION 0 Defaulting the Panel or Master user Code

This location allows you to default the panel, user codes and their properties, and bus-wired peripherals. Refer to Table 4 for the values, that can be programmed, and their actions.

[INSTALLER CODE] [*] [0] [*] [VALUE] [*]

Table 4: Defaulting Data

Value	Action
0	Will reset all locations and ID's to the factory default values. (Master User Code 1234)
1	Will default the Primary Master User Code back to 1234 - or 123456 if 6 digits are being used. Master User Code properties will also be defaulted.
2	Defaults ALL user codes and their properties.
3	Defaults ALL keypads.
4	Remove Missing Devices. Any missing devices (keypads, for example), will have its address freed up, making its address available for a new device when it is enrolled. This MUST be performed when replacing a faulty device. (You must wait for 30 seconds from device failure or removal.)
5	Default "Central Monitoring Mode". Defaults DTMF numbers, dialling options, reporting options, reporting code options and sets some options not to factory settings. (Implemented in vers.2)
6	Default "Private Reporting mode". (sets some options not to factory settings) (Implemented in vers.2)
7	Defaults all wireless zones and settings

Zones

Location 1 – 8 Individual Zone Type Setup

These locations allow you to program the zone types for zones 1-64. The zones are divided into 8 zones per location. After the zone type is programmed for zones 9 through 64, they will need to be assigned to a partition before being enabled.

Refer to Partition Options to see how to add zones to partitions and what options are available.

Each location represents a set of 8 zones:

- Location 1 zones 1-8 (X8)
- Location 2 zones 9-16 (X16)
- Location 3 zones 17-24 (X64)
- Location 4 zones 25-32 (X64)
- Location 5 zones 33-40 (X64)
- Location 6 zones 41-48 (X64)
- Location 7 zones 49-56 (X64)
- Location 8 zones 57-64 (X64)

Refer to **Table 5: Zone Types**

NOTE:

- If you require a panic zone whose status can be viewed on a keypad, Do NOT use the dedicated panic as it cannot be viewed on a keypad.
- Zones 1-8 are onboard zones.
- Zones 9-16 are plug-in expander zones.
- Zones 17-64 are expander zones. (Supported only by X64)

Table 5: Zone Types

Value	Zone Type
00	DISABLED A zone violation of a Disabled zone is ignored by the Alarm Panel and will not be indicated on the keypad.
01	PRIMARY ENTRY/EXIT ZONE Violations of an Entry/Exit zone are ignored during the exit delay period of the arming procedure. Violating an Entry/Exit zone when armed will initiate the entry delay period. If a valid User Code is not entered before the entry delay period expires, an alarm condition will be registered. Failure to exit through an Entry/Exit zone after arming will cause the panel to Stay Arm. This zone may also function as an Entry/Exit zone that is COMMON to two partitions. In such a case, should a user violate this zone and then disarm this partition, the OTHER partition will re-arm after the entry delay.
02	FOLLOWER ZONE A Follower zone is not monitored during the Entry/Exit delay period; therefore, it will not cause a violation. This allows the user to enter/exit via the Follower zone. A Follower zone will behave as an Instant zone while the panel is armed, and an Entry/Exit zone is not violated prior to violation of the Follower zone.
03	PANIC/PRIORITY ZONE Regardless of whether the panel is armed or not, a violation of a Priority zone will cause the Alarm Panel to register a panic condition. This zone type CANNOT be bypassed.
04	INSTANT ZONE Violation of an Instant zone will cause the Alarm Panel to register an alarm condition.
05	ARM/DISARM ZONE Violation of an Arm/Disarm zone will cause the panel to toggle between (away) armed and disarmed. It is typical to connect a momentary key-switch, or non-latching remote control unit to this zone. NOTE: A zone must be added to a partition in order for it to arm.
08	SECONDARY ENTRY/EXIT ZONE The Secondary entry delay will be activated if this zone is violated while the panel is armed.
09	Instant Fire Zone (New) Zone triggers on the first violation and triggers a standard fire alarm signal
10	FIRE ZONE Violation of a Fire zone will cause the siren to sound regardless of whether the panel is armed or not. The siren will sound intermittently (one second on, one second off). For correct operation, a programmable output programmed as a fire detector power output must be used to control power to the fire detector (refer to Table 36)
11	TAMPER ZONE Violation of a Tamper zone will be reported to the base station regardless of whether the panel is armed or disarmed. If the panel is armed, the siren will sound.
12	24 HOUR ALARM ZONE Regardless of whether the panel is armed or not, a violation of a 24 Hour Alarm zone will cause the Alarm Panel to register a panic condition.
13	WARNING ZONE Violation of a Warning zone will cause the siren to beep. The violation is logged in the event log but it is not reported to the base station. Warning zones may be included and will be counted when used as part of the cross-zone.
14	PUSH TO ARM ZONE Violation of a Push to Arm zone during the exit delay will immediately arm the panel.
15	OUTDOOR INSTANT ZONE Violation of an Outdoor Instant zone will cause the panel to register an alarm condition. NOTE: This is a reporting code and it functions in the same way as zone type 04.

How to program using the string method:

To program 8 zones at a time, fill in a row with the corresponding zone types (2 digits per type, found in **Table 5: Zone Types**) and enter these values as one long 16-digit string for location 1. This method can be used for the remaining 56 zones by noting that location 2 references zones 9 to 16, location 3 references zones 17 to 24, etc.

i.e. To program the defaulted zone types (Table 6) for the first 16 zones use the following:

```
[INSTALLER CODE] [*]
[1][*]                                reference zones 1 - 8
[0102040404040404][*]
[2][*]                                reference zones 9 - 16
[0000000000000000][*]
```

How to program using the sub-location method:

To program zones using the sub-location method, program 1 (as indicated by “[]” sub-location (followed by the [*] key) and then enter the zone type (followed by the [*] key). Then press the [*] key again to advance to the next sub-location. For sub-locations, the zone type does not have to be 2 digits, i.e. enter 1 or 01.

To repeat for further zones, enter the second zone number (followed by the [*] key) and then the zone type (followed by the [*] key). This can be repeated for all 64 zones.

i.e. To program the defaulted zone types for the first four zones use the following:

```
[INSTALLER CODE] [*]
[1][*]                                reference zones 1 - 8
[1][*][1] [*] [*]                    zone 1, zone type 1
[2][*][2] [*] [*]                    zone 2, zone type 2
[3][*][4] [*] [*]                    zone 3, zone type 4
[4][*][4] [*] [*]                    zone 4, zone type 4
```

How to program using the [*] key to advance:

A third method to program zones using the star advance method is to enter the location number corresponding to a group of 8 zones you wish to program. Each press of the [*] key will step through a zone.

i.e. To change zone 12 to an Instant zone, use the following:

```
[INSTALLER CODE] [*]
[2][*]                                reference zones 9 – 16
[*]                                    move to zone 10
[*]                                    move to zone 11
[*]                                    move to zone 12
[4][*]                                zone type 4
```

Table 6 represent the default zone types for the 64 zones represented in 2 different programming methods.

Table 6: Zone Types in String Format

Zones	Loc	Sub-loc	As Strings	Zone Type
1 - 8	1	n/a	0102040404040404	ref above table
9 - 64	2 - 8	n/a	0000000000000000	All Disabled

Table 7: Zone Types in Sub-location Format

Zone	Loc	Sub-Loc	As Sub-locations	Zone Type
1	1	1	01	Entry / Exit
2	1	2	02	Follower
3	1	3	04	Audible Instant
4	1	4	04	Audible Instant
5	1	5	04	Audible Instant
6	1	6	04	Audible Instant
7	1	7	04	Audible Instant
8	1	8	04	Audible Instant

The valid data range is: 00 – 05, 08, 10 – 15.

LOCATION 9 Trouble Display 2

This location determines which trouble conditions are indicated on the keypad by a flashing POWER LED. The POWER LED will only stop flashing once the trouble condition has been cleared. Trouble conditions will be reported if programmed to do so in locations 571 and 572, regardless of whether they are enabled for display.

To view, hold down the [7] key until the keypad beeps. See "Viewing Trouble Conditions" in the User manual.

Note: These trouble conditions cannot be viewed by LED Keypads

LED	Default	Action
1	OFF	AC fail monitored power supply
2	OFF	Low battery monitored power supply
3	OFF	Fuse fail on monitored power supply

➤ **AC Fail Monitored Power Supply**

This occurs when the monitored power supply does not receive any power from your mains electricity. Check if a power failure has occurred, or your transformer is not plugged in or faulty.

➤ **Low Battery Monitoring Monitored Power Supply**

This trouble condition will be caused by the battery voltage dropping below 11.3V.

➤ **Fuse Fail Monitoring**

This trouble condition indicates that the fuse on the monitored power supply has blown.

LOCATION 10 Zone Shutdown Count (default = 5)

This location determines the number of times a zone may be violated while the panel is armed before it is automatically bypassed. Disarming the panel will clear all bypassed zones.

The Zone Shutdown Count set here applies to all zones that have option 3 (shutdown zone) enabled in locations 101-164.

[INSTALLER CODE] [*] [1] [0] [*] [ZONE SHUTDOWN COUNT] [*]

The valid data range is: 1 – 15.

LOCATION 11 Programmable Zone Loop Response Time (default = 2)

The zone loop response time is the period for which a zone must remain violated before a violation is registered. The time is calculated in 12 millisecond increments starting at 12ms. A partial table between the values of 1 and 255 is shown in Table 8; times not shown on the table can be calculated as per the following example:

$198 \times 0.012 = 2.38$ seconds.

To program the time into this location, the format is [SSS].

[INSTALLER CODE] [*] [1] [1] [*] [ZONE LOOP RESPONSE TIME] [*]

The valid data range is: 1 – 255.

Table 8: Loop Response Time Data

Value	Response Time	Value	Response Time	Value	Response Time	Value	Response Time
1	12 ms	10	120 ms	60	720 ms	180	2.16 seconds
2	24 ms	12	144 ms	75	900 ms	210	2.52 seconds
3	36 ms	14	168 ms	90	1.08 seconds	240	2.88 seconds
4	48 ms	15	180 ms	120	1.44 seconds	255	3.06 seconds
5	60 ms	30	360 ms	150	1.80 seconds	105	1.26 seconds

LOCATION 12 Cross-zone Delay Time (default = 0030)

This location defines the cross-zone delay timer period in minutes and seconds, and it is used in conjunction with location 13. (This is an advanced location).

To program the time into this location, the format is [MMSS].

[INSTALLER CODE] [*] [1] [2] [*] [MMSS] [*]

The valid data range is: 00m00s – 59m59s.

LOCATION 13 Cross-zone Count (default = 3)

If the panel is armed and the total number of violations of zones programmed as cross-zones (locations 101-164) or a single cross-zone reaches this count within the time period programmed into location 12, an alarm condition will be registered.

[INSTALLER CODE] [*] [1] [3] [*] [CROSS-ZONE COUNT] [*]

The valid data range is: 1 - 15, with 0 to disable.

LOCATION 14 Global Options

This location allows you to configure the global options for the XSeries Alarm Panel. Table 9 shows the available options.

NOTE: For each enabled option, the corresponding locations that configures the option must be correctly programmed.

See Location 19: Extra Global Options for more global options

Table 9: Global Options Data

LED	Default	Action	LED	Default	Action
1	ON	A user assigned to any partition may cancel the siren	9	ON	Siren monitoring
2	OFF	Keypad trouble beep	10	OFF	Bus-wired peripheral tamper monitoring (Option 9 in location 16 must be enabled)
3	OFF	Telephone line monitoring	11	OFF	Onboard dedicated panic – silent
4	OFF	Keypad beep on successful reporting to the base station	12	ON	Low battery monitoring (Must be ON for option 13 to work)
5	ON	Keypad Fire, Medical and Panic Keys	13	ON	Low battery cut-out (See option 12)
6	ON	The display of bypassed and stay zones when armed	14	OFF	Bypassing with user code
7	OFF	Siren delay	15	OFF	Dedicated panic zone bypassing
8	ON	Box tamper monitoring	16	OFF	Remote transmitters to cancel panic

NOTE: If mains power is present, then the battery is monitored every 30 minutes and with no mains every minute. If the battery voltage drops below 10V, then the battery will cut-out if option 13 is enabled. If the battery voltage drops below 11V, then option 12 will be reported if it is enabled.

LOCATION 15 Mains Fail Reporting Delay (default = 0004)

In the event of a power failure (although instantly displaying the trouble indication) the panel will wait for this period of time before REPORTING the mains failure to the base station. This delay eliminates unnecessary reporting if the Mains power is removed for a short time period. It is important to note that a Mains restoral will only be reported if a Mains failure was reported first, i.e. the delay period was exceeded.

To program the time into this location:

[INSTALLER CODE] [*] [1] [5] [*] [HHMM] [*]

The valid data range is: 00h01m – 18h00m.

Note: The restoral event is reported and logged within a minute of Mains being restored.

LOCATION 16 Trouble Display Enable

This location determines which trouble conditions are indicated on the keypad when viewing the trouble display. A trouble condition is indicated by a flashing POWER LED. The POWER LED will only stop flashing once the trouble condition has been cleared. Trouble conditions will be reported if programmed to do so in locations 571 and 572, regardless of whether they are enabled for display.

To view, hold down the [7] key until the keypad beeps. See “Viewing Trouble Conditions” in the User manual.

Table 10: Trouble Display Options available for viewing

Explanation of Trouble Conditions

➤ Mains Fail

This occurs when the Alarm Panel does not receive any power from your mains electricity. Check if a power failure has occurred, or your transformer is not plugged in or faulty.

This trouble condition will only clear once the power has been restored.

➤ Reporting Communications Failure

This occurs when communication to the monitoring company is not successful.

The event will clear upon exiting the trouble viewing mode.

➤ Telephone Line Monitoring

The causes of this could be a fault, or short, on the phone line; or the phone line could be cut.

This trouble condition will only clear once the phone line restored.

➤ Siren Monitoring

This can occur when the siren has been removed or the siren fuse on the panel has blown.

This trouble condition will only clear once the siren or fuse has been replaced.

- **Low Battery Monitoring**
This trouble condition can be caused by a low battery voltage, a dead battery, or no battery. If the battery is there, try charging it. If this does not work, then the battery needs to be replaced.
This trouble condition will only clear once the battery voltage has been restored.
- **Aux 12V Monitoring**
This trouble condition indicates that the fuse has blown, or that there is a fault
This trouble condition will only clear once the fault has been restored.
- **Engineer's Reset**
An alarm condition has occurred, the Installer needs to come and clear the condition by entering an installer code. The panel cannot be armed until this has occurred, nor will the trouble condition clear.
- **Box Tamper**
The metal housing where the panel is stored has been opened.
To clear trouble condition, make sure the door to the housing is closed and then view the trouble condition.
- **Bus-wired Peripheral Tamper**
This trouble condition indicates that a keypad, remote receiver or bus-wired zone expander has been tampered with.
To clear this trouble condition, restore the tampered device and then view the tamper.
- **Bus-wired Peripheral Fail**
The panel has lost communication to one of the peripherals attached to it.
- **Bus-wired Peripheral Low Power / Battery**
Supply voltage to a peripheral has dropped below the recommended limit.
- **Wireless Device Battery**
This trouble condition indicates a wireless device's battery needs replacing
- **Wireless Device Supervision**
A wireless device has gone missing
- **Wireless Receiver RF Jam**
A signal has been detected on the same frequency which may cause signal loss
- **Wireless Device RSSI**
RSSI means a wireless device has checked in but the signal strength was very low
- **Tamper**
A device has reported being interfered with

LED	Default	Action
1	ON	Mains fail trouble display
2	OFF	Reporting communication fail trouble display
3	OFF	DTMF line monitoring trouble display
4	ON	On-board siren monitoring trouble display
5	ON	Low battery monitoring trouble display
6	OFF	Aux. 12V monitoring trouble display
7	OFF	Engineer's reset trouble display
8	ON	Box tamper trouble display
9	OFF	Bus-wired peripheral tamper trouble display
10	OFF	Bus-wired peripheral fail trouble display
11	OFF	Bus-wired peripheral low power/battery trouble display
12	ON	Wireless detector battery trouble
13	ON	Wireless detector supervision trouble
14	OFF	Wireless detector RF jam trouble
15	OFF	Wireless detector low RSSI trouble
16	OFF	Zone tamper trouble condition

LOCATION 17 Siren Time Out Period (default = 0200)

The siren time out period is the period for which the siren will sound after an activated.
To program the time into this location, the format is [MMSS].

[INSTALLER CODE] [*] [1] [7] [*] [MMSS] [*]

The valid data range is: 00m01s – 59m59s.

LOCATION 18 Siren Delay (default = 0200)

This location sets the siren delay period between when an audible alarm condition is registered, and the siren is activated. The alarm condition will however be reported to the base station as soon as it occurs. Panic zones and Fire zones will cause an immediate siren even if siren delay is programmed.

Option 7 in location 14 (Global Options) must be enabled for the siren delay to have an effect.

To program the time into this location, the format is **[MMSS]**.

[INSTALLER CODE] [*] [1] [8] [*] [MMSS] [*]

The valid data range is: 00m01s – 59m59s.

LOCATION 19 Extra Global Options

This location allows you to configure more global options for the XSeries Alarm Panel.

Table 11: Extra Global Options

LED	Default	Action
1	OFF	Zone violation when wireless supervision loss is detected (Wireless detector)
2	Reserved	
3	OFF	24Hour zone report only (Makes all 24Hr zone silent)
4	OFF	Box tamper always triggers the siren
5	OFF	Bus-wired peripheral tamper always triggers the siren
6	OFF	Zone tamper always triggers the siren
7	Reserved	
8	OFF	Disable dedicated panic zone

LOCATION 20 Keypad Lockout Count (default = 4)

If a partition has a keypad lockout enabled, the value entered in this location determines the number of consecutive incorrect codes to activate a keypad lockout. The keypad will remain locked for the time programmed in location 21. Activating a Keypad Panic (or dedicated panic zone or entering a duress code) will unlock the keypad.

Option 4 in locations 221-228 (Extended Partition Options) must be enabled for the keypad lockout count to have an effect.

[INSTALLER CODE] [*] [2] [0] [*] [KEYPAD LOCKOUT COUNT] [*]

The valid data range is: 2 – 16.

LOCATION 21 Keypad Lockout Time (default = 0030)

The value determines the period for which the keypad will remain locked out if the keypad lockout count programmed into location 20 has been exceeded. After this period has elapsed, a locked-out keypad will return to an unlocked state. Keypad lockout is enabled by partition; refer to locations 221-228 for extended partition options, but this period applies to all partitions.

To program the time into this location, the format is **[MMSS]**.

[INSTALLER CODE] [*] [2] [1] [*] [MMSS] [*]

The valid data range is: 00m01s – 59m59s.

LOCATION 22 Keypad Sleep Delay (default = 0500)

This location sets the time out period before the keypad enters sleep mode. After the delay period, if there is no keypad activity (on any keypad) the backlighting and all other status and alarm LEDs will turn off.

The following events will bring a keypad out of sleep mode: Zone violations/restorals, Tamper violations/restorals, or key presses.

To program the time into this location, the format is **[MMSS]**.

[INSTALLER CODE] [*] [2] [2] [*] [MMSS] [*]

The valid data range is: 00m01s – 59m59s.

LOCATION 23 User, Installer & Maintenance Code - Number of Digits (default = 4)

This location determines whether user, installer and maintenance codes are 4 or 6 digits in length. The value programmed into this location has no effect on the download code, which is always 4-digits in length.

If the code length is changed from 6 to 4, then all user codes are automatically set to their default values as per Table 12. This is to avoid duplicate codes being inadvertently created when they have the same first 4 digits.

Table 12: Number of Digits Data

Code	Old four-digit code	New six-digit code
Installer Code	9999	999999
Maintenance Code	8888	888888
Master User Code 1	1234	123456

[INSTALLER CODE] [*] [2] [3] [*] [NUMBER OF DIGITS] [*]

The valid data range is either 4 or 6.

LOCATION 24 Number of Account Code Digits (default = 4)

This location sets the account code length to either 4 or 6 digits. If the length of your account codes is 4 digits and then they are changed to 6 digits, the last two digits will be set to 0.

[INSTALLER CODE] [*] [2] [4] [*] [NUMBER OF DIGITS] [*]

The valid data range is: 4 or 6.

Daylight Savings**LOCATION 25 Month to Start Daylight Saving (default = 0)**

Select the month for Daylight Saving to commence, as per Table 13.

Table 13: Month Data

Value	Month	Value	Month	Value	Month	Value	Month
0	Disabled	3	March	6	June	9	September
1	January	4	April	7	July	10	October
2	February	5	May	8	August	11	November
						12	December

[INSTALLER CODE] [*] [2] [5] [*] [MONTH] [*]

NOTE: If this location is disabled, then by default, locations 26 and 27 will also be disabled. This means that even if you put values into locations 26 and 27, daylight savings will not commence.

LOCATION 26 Day of Week to Start Daylight Saving (default = 1)

Select the day of the week for Daylight Saving to commence, as per Table 14.

Table 14: Day of Week Data

Value	Day	Value	Day
1	Monday	5	Friday
2	Tuesday	6	Saturday
3	Wednesday	7	Sunday
4	Thursday		

[INSTALLER CODE] [*] [2] [6] [*] [DAY] [*]

LOCATION 27 Week of Month to Start Daylight Saving (default = 1)

Select the week of the month for Daylight Saving to commence as per Table 15. To set the last week of each month, set the value to 5.

Table 15: Week of Month Data

Value	Day	Value	Day
1	Week One	4	Week Four
2	Week Two	5	Last Week
3	Week Three		

[INSTALLER CODE] [*] [2] [7] [*] [WEEK] [*]

The valid data range is: 1 – 5.

LOCATION 28 Month to End Daylight Saving (default = 0)

Select the month as per Table 13, to end Daylight Saving.

[INSTALLER CODE] [*] [2] [8] [*] [MONTH] [*]

The valid data range: 1 – 12, with 0 to disable.

NOTE: If this location is disabled, then by default, locations 29 and 30 will also be disabled. This means that even if you put values into locations 29 and 30, daylight savings will not start.

LOCATION 29 Day of Week to End Daylight Saving (default = 1)

Select the day of the week as per Table 14, to disable Daylight Saving.

[INSTALLER CODE] [*] [2] [9] [*] [DAY] [*]

The valid data range is: 1 – 7.

LOCATION 30 Week of Month to End Daylight Saving (default = 1)

Select the week of the month as per Table 15, to disable Daylight Saving.

[INSTALLER CODE] [*] [3] [0] [*] [WEEK] [*]

The valid data range is: 1 – 5.

LOCATION 31 Daylight Saving Time Offset (default = 60)

Enter the daylight-saving time offset that will be in force while daylight saving is enabled.

[INSTALLER CODE] [*] [3] [1] [*] [DAYLIGHT SAVING TIME OFFSET] [*]

The valid data range is: 0 – 250.

Miscellaneous– Advanced

LOCATION 32 Auto Test Report Interval (default = 7)

The value programmed into this location determines the duration of time between Automatic System Tests. Input the value as per Table 16.

[INSTALLER CODE] [*] [3] [2] [*] [AUTO TEST REPORT INTERVAL] [*]

Table 16: Auto Test Interval Data

Value	Time	Value	Time	Value	Time	Value	Time	Value	Time	Value	Time
0	1H	4	6H	8	2D	12	6D	16	10D	20	14D
1	2H	5	8H	9	3D	13	7D	17	11D		
2	3H	6	12H	10	4D	14	8D	18	12D		
3	4H	7	1D	11	5D	15	9D	19	13D		

LOCATION 33 Auto Test Time (default = 0010)

Enter the time when the auto test will be reported. The format is [HHMM] based on a 24-hour clock. (All 4 digits must be entered.)

[INSTALLER CODE] [*] [3] [3] [*] [HHMM] [*]

The valid data range is: 00h00m – 23h59m.

EXAMPLE: If a value of [13] was programmed into location 32 and [1400] was programmed into this location, the auto test would be sent every 7 days at 2:00pm.

LOCATION 34 Download Code Default Disable (default = 0)

This location allows you to set whether the download code is defaulted back to 9999 if the panel is defaulted. Refer to Table 17 for the values that can be programmed.

[INSTALLER CODE] [*] [3] [4] [*] [DOWNLOAD CODE DEFAULT DISABLE] [*]

Table 17: Download Code Disable Data

Value	Action
0	Enable Download code defaulting
10	Disable Download code defaulting

LOCATION 35 Hardware Default Switch Disable (default = 0)

This location allows you to select whether the Hardware Default Switch is enabled. Refer to Table 18 for the values that can be programmed. For the detailed operation of this switch, refer to Hardware default switch

[INSTALLER CODE] [*] [3] [5] [*] [HARDWARE DEFAULTSWITCH DISABLE] [*]

Table 18: Default Switch Disable Data

Value	Action
0	Enable Hardware Default Switch
10	Disable Hardware Default Switch

LOCATION 36 Zone Status Verify Time (Default = 10min)

This is the time a zone is monitored for a restore. If the zone does not restore, the system will wait the time entered in this location before sending another burglary event after the siren has timed out.

Note: Must be enabled in Location 221-228 option 8 and the count must be set in location 37

Data entered as mm:ss.

Valid entry is from 00:01 to 59:59. The default is 10min.

LOCATION 37 Zone Status Verify Count (Default =0)

The number of times a burglary event will be sent if the zone does not restore once the siren times out. After the number in this location is reached the zone will be ignored until it restores.

Data entered as number count.

Valid entry is from 0 to 16. Default is 0.

Communications Setup - Advanced

Quick arming reporting notes:

- If the system is armed by zone, the system will report a close by **user 129**.
- If the system is armed using the quick arm key [1], the system will report a close by **user 130**.
- If the system is armed using the quick stay key [5], the system will report a close by **user 131**.
- If the system is armed using the stay arm and go key [6], the system will report a close by **user 132**.
- If the system is armed by means of the auto arm function, the system will report a close by **user 133**.
- If the system is armed with the download software, the system will report a close by **user 134**.
- These user numbers are hard coded, and they are used when the above actions are reported to a monitoring company.
- For these codes to be report, Location 581 – 588 option 7 must be enabled.

LOCATION 45 Communication Delay (default = 0020)

This location sets the period that the panel will wait before reporting zone violations and restorals. If the alarm is cancelled within this time, violations and restorals will not be reported. Violations will however be logged in the event log. Panic events will be reported instantly – regardless of any selected delay period.

Option 3 in locations 221-228 (Extra Partition Options) must be enabled for the communication delay to have an effect. To program the time into this location, the format is [MMSS].

[INSTALLER CODE] [*] [4] [5] [*] [MMSS] [*]

The valid data range is: 00m01s – 59m59s.

LOCATION 47 Number of Dial Attempts (default = 6)

This location determines the maximum number of dial attempts that the panel will make to contact the base station. This applies to any of the four phone numbers programmed into locations 51-54.

If this location is disabled, the Alarm Panel will not report to any base stations on the DTMF or Serial port, the HYPY Plug-on will still report.

[INSTALLER CODE] [*] [4] [7] [*] [NUMBER OF DIAL ATTEMPTS] [*]

The valid range of data: 1 – 9, with 0 to disable.

DTMF Phone Numbers

The DTMF number in location 51 will be dialed as many times as entered in location 47, default is 6 times, and will wait for the time set in location 56 before dialling again if no response is received when dialling.

NOTES ON HOW TO PROGRAM A PHONE NUMBER:

Enter numbers consecutively with no other key presses between each digit.

EXAMPLE: Phone number be dialed **1234**:

Table 19: Phone Number Example

Data entered	Explanation
[INSTALLER CODE][*]	To enter program mode
[5][1][*]	To enter location 51 (phone number 1)
[1][2][3][4]	Number to be dialed
[*]	To save the number
[#]	To exit installer menu

LOCATION 51 DTMF Communication Number to be dialed

Program this location to set the DTMF number. A maximum of 10-digits can be entered. Enter the digits consecutively and after the last digit has been entered, save with the [*] key.

[INSTALLER CODE] [*] [5] [1] [*] [TELEPHONE NUMBER] [*]

LOCATION 56 Time Between Dial Attempts

This location sets the time the panel will wait before dialling again if the first attempt failed to contact the base station and location 47 number of dial attempts has been set to 2 or more.

[INSTALLER CODE] [*] [5] [6] [*] [m][m][s][s] [*]

Default value: 0010 = 10 seconds

Account Codes

NOTE: Communication devices can connect in two different ways to the XSeries serial alarm system and have their own account locations.

1. Serially connected device via the five-pin serial comm port and account codes must be entered into locations 61 to 68 depending on the partition.
2. Plug on modules account codes must be entered into locations 71 to 78 depending on the partition.

LOCATIONS 61-68 Account Codes for Plug on Module (Partitions 1- 8)

The serial communication account code is used for reporting to the 5-pin serial port.

Each location represents a partition:

- | | | |
|------------------------------|------------------------------|------------------------------|
| ➤ Location 61 is partition 1 | ➤ Location 62 is partition 2 | ➤ Location 63 is partition 3 |
| ➤ Location 64 is partition 4 | ➤ Location 65 is partition 5 | ➤ Location 66 is partition 6 |
| ➤ Location 67 is partition 7 | ➤ Location 68 is partition 8 | |

[INSTALLER CODE] [*] [LOCATION] [*] [PRIMARY ACCOUNT CODE] [*]

NB: If the account code is 0000 no reporting will take place

NOTE: The length of the account code, either 4 or 6 digits, is set in location 24. If the length of the account code is changed from 4 to 6 digits, then the account codes will automatically have 00 at the end of them to make them 6 digits in length.

LOCATIONS 71-78 Account Code Serial Communication Port (Partitions 1-8)

The plug-on module communication account code is used for reporting to the module plugged directly into the system.

Each location represents a partition:

- | | | |
|------------------------------|------------------------------|------------------------------|
| ➤ Location 71 is partition 1 | ➤ Location 72 is partition 2 | ➤ Location 73 is partition 3 |
| ➤ Location 74 is partition 4 | ➤ Location 75 is partition 5 | ➤ Location 76 is partition 6 |
| ➤ Location 77 is partition 7 | ➤ Location 78 is partition 8 | |

[INSTALLER CODE] [*] [LOCATION] [*] [SECONDARY ACCOUNT CODE] [*]

NB: If the account code is 0000 no reporting will take place

NOTE: The length of the account code, either 4 or 6 digits, is set in location 24. If the length of the account code is changed from 4 to 6 digits, then the account codes will automatically have 00 at the end of them to make them 6 digits in length.

LOCATIONS 101-164 Zone Type Properties (Zones 1 – 64)

Locations 101-164 are used to configure properties for zones 1-64 respectively. Each location contains a bitmap of 5 zone type properties, as per Table 20.

Tamper by Zone

Individual zones may be enabled to monitor tamper so if the panel is unarmed and a tamper condition occurs, the siren will not activate but a tamper condition will be reported. If the panel is armed and a tamper condition occurs on the zone, an audible alarm condition will register, and a tamper condition will be reported.

Cross-zoning

This feature is useful for reducing false alarms. Violating zones with the cross-zone property enabled will not immediately generate an alarm. The Cross-zone Delay Time is started as per location 12. Depending on the value programmed into location 13 (Cross-zone Trip Count), the zone (or any other zone with cross-zone option enabled) must trip the number of times programmed into location 13 before an alarm is generated. An alarm will also be generated should any single zone remain violated for the entire delay period (location 12). An Entry/Exit cannot be configured as a cross-zone. Each cross-zone will have its own timer.

Shutdown Zone

While armed, if the number of alarm violations generated by a shutdown zone equals the shutdown count (location 10), the Alarm Panel no longer reports violations of that shutdown zone. The shutdown counter will reset when the system is disarmed and re-armed, it can be programmed to try and re-enable the zone automatically when the 24 hour self-test report is generated.

Silent Zone

This property allows any zone that would ordinarily activate the siren to be programmed as a Silent zone i.e. the violation of a Silent zone, while the system is armed, will not activate the siren. However, the relevant reporting code (if programmed) will still be reported. All zones can be programmed as a Silent zone, except for the Fire zone.

Chime Zone

The chime mode allows the user to monitor nominated zones while the system is disarmed. The keypad buzzer will sound five times when the nominated zone is violated - the siren will NOT sound and no alarm condition will be reported.

Zone Bypassing

This option allows a zone to be disabled/bypassed or if it is covering a sensitive area not to be disabled.

Zone always triggers Output

This option will trigger the allocated output when the alarm is armed or not.

Zone Always Triggers

This option if enabled, will trigger a selected output when a zone is violated no matter the state of the alarm panel and if not selected the output will only trigger when the alarm system is armed.

Stay Profile

Stay zones are zones that are bypassed automatically when the system is "STAY ARMED". To avoid triggering the alarm, zones such as bedrooms that are protected by Passive Infra-Red (PIR) detectors or windows that may be opened, must be bypassed when "staying at home".

Stay zones need only be programmed once. Each time the system is armed in the Stay Mode the pre-selected stay zones will be bypassed automatically. The panel allows for 4 unique STAY PROFILES to be stored, consisting of a pre-selected combination of STAY and BUZZ zones, to suit a specific STAY ARM requirement. STAY and BUZZ zones can be programmed for each profile only once the profile has been selected.

Buzz Profile

Violation of a Buzz zone when Stay Armed will cause the keypad buzzer to sound for a period of 30 seconds during which time a valid user code must be entered. If a valid user code is not entered during this period, the system will register an alarm condition. This feature helps prevent unnecessary false alarms.

If an Entry/Exit zone is programmed as a Buzz zone, violation of the Entry/Exit zone (when the panel is Stay Armed) will cause the keypad buzzer to sound for the duration of the entry delay time (in place of the default 30 seconds). This, if the panel is Stay Armed, allows the user to enter the premises and disarm the panel. If it is not programmed as a Buzz zone, the alarm will be triggered immediately. If the panel was stay armed, a violation of the Entry/Exit zone will always start the Entry/Exit delay and will not buzz.

Table 20: Zone Type Properties Data

LED	Default	Zone Properties
1	OFF	Tamper by Zone
2	OFF	Cross-zone
3	OFF	Shutdown Zone
4	OFF	Silent Zone
5	OFF	Chime Zone
6	ON	Zone bypassing
7	OFF	Zone always triggers PGM
8	OFF	Reserved

LED	Default	Zone Properties
9	OFF	Stay Profile 1
10	OFF	Stay Profile 2
11	OFF	Stay Profile 3
12	OFF	Stay Profile 4
13	OFF	Buzz Profile 1
14	OFF	Buzz Profile 2
15	OFF	Buzz Profile 3
16	OFF	Buzz Profile 4

NOTE: Please see section 14 of the User manual for more information on how stay profiles and how to switch between them.

No Movement– Advanced

LOCATION 165 No Movement Auto Arm Time Out (default =0000)

If no violations are registered for the period specified in this location, then the alarm will auto arm. This may be used if you forget to arm when leaving for work; the alarm will then automatically away arm if no violations. This function is only available if values have been programmed into locations 166 and 167.

This No Movement Auto Arm event reports a close event, using user number 133, but only for CID or SIA reporting.

Enter a 2-digit duration in hours for each of the 8 partitions and program as a 16-digit string, followed by the [*] key.

[INSTALLER CODE] [*] [1] [6] [5] [*] [PARTITION NO.] [*] [HHMM] [*]

The valid data range is: 00h00m to 23h59m. Partition no. is: 1-8.

NOTE: If this location is disabled, then by default, locations 166 and 167 will also be disabled.

LOCATION 166 No Movement Auto Arm Start (default = 0000)

Program the start time to start checking for no movement. For example, if you leave your premises at 06:50 am, program the start time to be 07:00.

Enter a 4-digit time [HHMM] for each of the 8 partitions and program as a 32-digit string, followed by the [*] key.

[INSTALLER CODE] [*] [1] [6] [6] [*] [PARTITION NO.] [*] [HHMM] [*]

The valid data range: 00h00m – 23h59m. Partition no. is: 1-8.

LOCATION 167 No Movement Auto Arm End (default = 0100)

Program the end time to stop checking for no movement. For example, using 07:00 programmed into location 166 and if 2 hours is needed, then program 09:00.

Enter a 4-digit time [HHMM] for each of the 8 partitions and program as a 32-digit string, followed by the [*] key.

[INSTALLER CODE] [*] [1] [6] [7] [*] [PARTITION NO.] [*] [HHMM] [*]

The valid data range: 00h00m – 23h59m. Partition no. is: 1-8.

LOCATION 168 No Movement Medical Alarm Time Out (default = 0000)

If no movement is detected, while the panel is disarmed, for the period specified here then the alarm will activate.

This function is only available if values have been programmed into locations 169 and 170.

This No Movement Medical Alarm event reports a medical event, (see location 339 if custom reporting codes have been used).

EXAMPLE: This may be used to monitor the elderly who have become incapacitated and are unable to sound the panic.

Enter a 2-digit duration in hours for each of the 8 partitions and program as a 16-digit string, followed by the [*] key.

[INSTALLER CODE] [*] [1] [6] [9] [*] [PARTITION NO.] [*] [HHMM] [*]

The valid data range is: 00h00m to 23h59m. Partition no. is: 1-8.

NOTE: If this location is disabled, then by default, locations 169 and 170 will also be disabled.

LOCATION 169 No Movement Medical Alarm Start (default = 0000)

The start time can be set for when you know that the person will be awake and active.

Program the start time to start checking for movement. For example, you expect a person to be awake at 6 am, program the start time to be 06:00.

Enter 4-digit time [HHMM] for each of the 8 partitions and program as a 32-digit string, followed by the [*] key.

[INSTALLER CODE] [*] [1] [6] [9] [*] [PARTITION NO.] [*] [HHMM] [*]

The valid data range: 00h00m – 23h59m. Partition no. is: 1-8.

LOCATION 170 No Movement Medical Alarm End (default = 0100)

Program the end time to stop checking for movement. For example, using 06:00 programmed into location 169 and if 2 hours is needed, then program 08:00.

Enter a 4-digit time [HHMM] for each of the 8 partitions and program as a 32-digit string, followed by the [*] key.

[INSTALLER CODE] [*] [1] [7] [0] [*] [PARTITION NO.] [*] [HHMM] [*]

The valid data range: 00h00m – 23h59m. Partition no. is: 1-8.

LOCATION 171 to 178 No Movement Auto Arm/Medical Alarm Days

Choose which days of the week that you want the, arm on no movement or medical alarm to be enabled.

Table 21: Arm/ Disarm Days Data

LED	Auto ARM Days of the Week
1	Monday
2	Tuesday
3	Wednesday
4	Thursday
5	Friday
6	Saturday
7	Sunday
All OFF	(Arm Day Disabled)

LED	Medical Days of the Week
9	Monday
10	Tuesday
11	Wednesday
12	Thursday
13	Friday
14	Saturday
15	Sunday
All OFF	(Disarm Day Disabled)

Location 180 Auto Arm Time (default = 2400)

This location sets the time at which a partition will auto arm. To disable this location, enter 2400 as the time.

EXAMPLE: To auto arm at 11:35pm, enter 2335. All four digits must be entered, including any leading zeros (0100 = 1 am).

Enter a 4-digit time for each of the 8 partitions and program as a 32-digit string, followed by the [*] key.

[INSTALLER CODE] [*] [1] [8] [0] [*] [PARTITION NO.] [*] [HHMM] [*]

The valid data range is: 00h00m – 23h59m, with 24h00m to disable. Partition no. is: 1-8.

LOCATIONS 181 - 188 Auto Arm/Disarm Days (default = all OFF)

These bitmapped locations set the days on which the selected partition will auto arm and disarm at the times programmed in locations 180 and 189 respectively. Refer to Table 22 for the values

Each location represents a partition:

- Location 181 is partition 1
- Location 182 is partition 2
- Location 383 is partition 3
- Location 184 is partition 4
- Location 185 is partition 5
- Location 186 is partition 6
- Location 187 is partition 7
- Location 188 is partition 8

Table 22: Arm/ Disarm Days Data

LED	ARM Days of the Week
1	Monday
2	Tuesday
3	Wednesday
4	Thursday
5	Friday
6	Saturday
7	Sunday
All OFF	(Arm Day Disabled)

LED	DISARM Days of the Week
9	Monday
10	Tuesday
11	Wednesday
12	Thursday
13	Friday
14	Saturday
15	Sunday
All OFF	(Disarm Day Disabled)

Select the days to ARM (LEDs 1-7) and DISARM (LEDs 9-15) by toggling them on/off.

LOCATION 189 Auto Disarm Time (default = 2400)

This location sets the time at which the partition will auto disarm. To disable, enter 2400.

EXAMPLE: To auto disarm at 06:00 am, enter 0600. All four digits must be entered, including any leading zeros (0100 for 1 am).

Enter a 4-digit time for each of the 8 partitions and program as a 32-digit string, followed by the [*] key.

[INSTALLER CODE] [*] [1] [8] [9] [*] [PARTITION NO.] [*] [HHMM] [*]

The valid data range is: 00h00m – 23h59m, with 24h00m to disable. Partition no. is: 1-8.

NOTE: For this auto disarm to be active; partition option 15 must be enabled in locations 211-218 and the appropriate disarm days) selected in locations 181-188.

LOCATION 190 Auto Arm Delay (default = 0200 i.e. 2 minutes)

This location sets the delay period for the keypad buzzer warning, which is initiated before the panel auto arms. At the completion of the Auto Arm Delay, the panel will arm. A valid user code entered during the delay period will cancel the auto arming.

Enter a 4-digit time for each of the 8 partitions and program as a 32-digit string, followed by the [*] key.

[INSTALLER CODE] [*] [1] [9] [0] [*] [PARTITION NO.] [*] [MMSS] [*]

The valid data range is: 00m01s – 59m59s. Partition no. is: 1-8.

Security Codes**LOCATION 197 Installer Code (default = 9999)**

This location is used to change the installer code to a code that is preferable.

[INSTALLER CODE] [*] [1] [9] [7] [*] [NEW INSTALLER CODE] [*]

NOTE: Refer to location 23 page 20 to set the number of digits in the installer code.

LOCATION 198 Download Code (default = 9999)

This location is used to change the download code to a code that is preferable.

The download code (in conjunction with the installer code) is required for download access to the Alarm Panel.

A value of [10] programmed into location 34 will prevent the download code from being defaulted when performing a hardware default.

[INSTALLER CODE] [*] [1] [9] [8] [*] [NEW DOWNLOAD CODE] [*]

NOTE: If the panel is defaulted, the download code will revert to 9999. The download code is 4-digits in length.

LOCATION 199 Maintenance Code (default = 8888)

Users can be given limited access to installer mode by entering the maintenance code.

Panel functions that can be edited in maintenance mode are:

- Siren time
- Keypad lockout count
- Daylight savings settings
- No zone activity auto arm
- Siren Delay
- Keypad Sleep delay
- Partition auto arm settings
- No zone activity alarm settings

[INSTALLER CODE] [*] [1] [9] [9] [*] [NEW MAINTENANCE CODE] [*]

NOTE: Refer to location 23 page 20 to set the number of digits in the maintenance code.

Partition Options**LOCATIONS 201 – 208 Partition Zone Allocation**

Program these locations to allocate zones to each of the 8 partitions. Lit zone number LEDs represent the zones allocated to the selected partition. The zones are displayed as 4 pages of 16 zones each as per Table 23. To scroll to the next page of 16 zones, press the [*] key.

Zones are common, which means that one zone can be allocated to more than one partition.

The keypad start zone in location 241 needs to be programmed for keypads displaying zone numbers higher than 16.

Each location represents a partition number:

- Location 201 is partition 1
- Location 202 is partition 2
- Location 203 is partition 3
- Location 204 is partition 4
- Location 205 is partition 5
- Location 206 is partition 6
- Location 207 is partition 7
- Location 208 is partition 8

Figure 2 and Figure 3 show the order the LEDs display to show you which zones you are viewing as per Table 23.

Figure 2: Paging Indication on the Classic Keypad

ARMED ② ③ AWAY
READY ① ④ POWER

Figure 3: Paging Indication on the Curved Keypad

4	1	2	3
Pwr	Rdy	Arm	Away

Table 23: Zones per Partition Page

Page	1		2		3		4	
LED	READY		ARM		AWAY		POWER	
Zones	1	9	17	25	33	41	49	57
	2	10	18	26	34	42	50	58
	3	11	19	27	35	43	51	59
	4	12	20	28	36	44	52	60
	5	13	21	29	37	45	53	61
	6	14	22	30	38	46	54	62
	7	15	23	31	39	47	55	63
	8	16	24	32	40	48	56	64

LOCATIONS 211 – 218 Partition Arm Options (Partitions 1 – 8)

These locations are used to configure arm options for each partition. Refer to Table 24 page 30 for the values that can be selected.

Each location represents a partition:

- Location 211 is partition 1
- Location 212 is partition 2
- Location 213 is partition 3
- Location 214 is partition 4
- Location 215 is partition 5
- Location 216 is partition 6
- Location 217 is partition 7
- Location 218 is partition 8

Quick Arm:

This option allows the user to arm the panel by holding down the [1] key for three seconds. The keypad will beep once to indicate that the arm sequence has begun.

Force Arm:

With this option enabled, the panel will arm with violated zones e.g. an open window. This forces any violated zones to be temporarily bypassed when the panel arms. If such bypassed zones restore during the arm cycle (the window is closed, for example), the zone is automatically re-activated (un-bypassed) and a subsequent violation will trigger an alarm.

Siren Toot on Away Arm / Disarm:

This option allows the user an audible confirmation that arming or disarming of the panel has occurred. The siren is programmed to give a short beep after successful arming, and two short beeps after disarming. This is useful when used in conjunction with remote or key-switch arming/disarming.

Engineer Reset:

Enabling this option will prevent the panel from being rearmed after an alarm condition has occurred. In order to re-arm the panel, the installer will be required to enter a valid installer code.

If option 7 is set in location 16, an engineer reset trouble condition will also be displayed on the keypad.

Table 24: Partition Arm Options Data

LED	Default	Action
1	OFF	Instant Arm
2	ON	Instant Key-switch Arm
3	ON	Quick Away Arm Key
4	ON	Quick Stay Arm Key
5	ON	Auto Stay Arm if No Exit Zone is Triggered*
6	OFF	Auto Stay Arm if No Exit Zone is Triggered When Arming with a Key-switch *
7	OFF	Forced Arm
8	ON	Zone Bypassing
9	OFF	Arm with Zones in the Entry Route Violated
10	OFF	Siren Toot on Arm
11	OFF	Siren Toot on Disarm
12	ON	Entry Beep
13	ON	Exit Beep
14	OFF	Engineer's Reset
15	OFF	Auto Disarm
16	OFF	Opening/Closing User Reporting

LOCATIONS 221 – 228 Extra Partition Options (Partitions 1 - 8)

These locations are used to configure extended options for each partition. Refer to Table 25 for the values that can be selected.

Each location represents a partition:

- Location 221 is partition 1
- Location 222 is partition 4
- Location 227 is partition 7
- Location 222 is partition 2
- Location 225 is partition 5
- Location 228 is partition 8
- Location 223 is partition 3
- Location 226 is partition 6

Table 25: Extended Partition Options Data

LED	Default	Action
1	OFF	Automatic Re-enabling of Shutdown Zones at the Time of the Dialler test
2	OFF	Bypassing of Common Zones
3	OFF	Delay Before Communications
4	OFF	Keypad Lockout
5	OFF	Silent Keypad Panic
6	OFF	Toot on Successful Closing on DTMF
7		Reserved
8	OFF	Send Zone Restoral Immediately (On = Send restoral after siren time out)

Delays

LOCATION 230 Exit Delay Period (default = 0030)

The exit delay period is the amount of time between arming the panel and successfully exiting the premises without violating Entry/Exit and Follower zones.

The exit delay will begin after the system is armed by either:

- Entering a valid user code
- Pressing the [1] key and holding it down until the system is armed
- Pressing the [6] key and holding it down until the system is armed

Enter a 4-digit exit delay period for each of the 8 partitions and program as a 32-digit string, followed by the [*] key.

[INSTALLER CODE] [*] [2] [3] [0] [*] [PARTITION NO.] [*] [MMSS] [*]

The valid data range is: 00m00s – 59m59s.

Partition no. is: 1-8.

LOCATION 231 Primary Entry Delay Period (default = 0030)

The primary entry delay begins after the violation of a Primary Entry/Exit zone. During this delay, it is permissible to violate Follower zones without causing an alarm condition.

If a Follower zone is violated without a prior Entry/Exit zone violation, it will be treated as an Instant zone. If an Instant zone is violated during this period, an alarm condition will immediately be registered.

Enter a 4-digit entry delay period for each of the 8 partitions and program as a 32-digit string, followed by the [*] key.

[INSTALLER CODE] [*] [2] [3] [1] [*] [PARTITION NO.] [*] [MMSS] [*]

The valid data range is: 00m00s – 59m59s. Partition no. is: 1-8.

LOCATION 232 Secondary Entry Delay Period (default = 0030)

The secondary entry delay begins after the violation of a Secondary Entry/Exit zone. During this delay, it is permissible to violate Follower zones without causing an alarm condition.

Enter a 4-digit entry delay period for each of the 8 partitions and program as a 32-digit string, followed by the [*] key.

[INSTALLER CODE] [*] [2] [3] [2] [*] [PARTITION NO.] [*] [MMSS] [*]

The valid data range is: 00m00s – 59m59s. Partition no. is: 1-8.

Options to Configure Keypads

LOCATION 240 Keypad Partition (default = Partition 1)

Program this location to allocate each keypad to a partition. Enter the partition number to which each keypad, with an ID 1-8, must be allocated. To view the ID of a keypad, refer to location 243 below.

Enter 1 digit for each of the 8 keypads and program as an 8-digit string, followed by the [*] key.

[INSTALLER CODE] [*] [2] [4] [0] [*] [KEYPAD NO.] [*] [PARTITION NO.] [*]

The valid data range is: 1 – 8. Partition no. is: 1-8.

LOCATION 241 Keypad Display Start Zone (default = Zone 1)

The zones which a LED keypad displays is determined by programming the keypad start zone location. The number programmed into this location is the zone which will be assigned to LED 1 on the keypad. The keypad will display subsequent zones in order. The keypad will only display zones belonging to its partition.

Enter a 2-digit display start zone (01 – 64) for each of the 8 keypads and program as a 16-digit string, followed by the [*] key.

[INSTALLER CODE] [*] [2] [4] [1] [*] [KEYPAD NO.] [*] [START ZONE] [*]

The valid data range is: 01 – 64.

NOTE: This only applies to LED keypads and not LCD keypads.

LOCATION 242 Keypad Zone Number (default = 0 i.e. Disabled)

A keypad zone must be allocated to any zone number (1 – 64), before it can be used. The corresponding zone type must be programmed in locations 1 – 8 and the properties configured in locations 101 – 164. If you configure a keypad to a zone number that is already a wired zone, then the keypad will take priority on the zone number.

Enter a 2-digit zone number (01 – 64) for each of the 8 keypads and program as a 16-digit string, followed by the [*] key.

[INSTALLER CODE] [*] [2] [4] [2] [*] [KEYPAD NO.] [*] [ZONE NO.] [*]

The valid data range: 01 – 64.

LOCATION 243 View Keypad ID

View the data in this location to determine the Keypad ID (1 – 8).

[INSTALLER CODE] [*] [2] [4] [3] [*]

NOTE: This is a read-only location and no data no can be changed.

LOCATIONS 251 – 258 Keypad Options

These locations are used to configure options for a keypad.

Each location represents a keypad:

- Location 251 is keypad 1 ➤ Location 252 is keypad 2 ➤ Location 253 is keypad 3
- Location 254 is keypad 4 ➤ Location 255 is keypad 5 ➤ Location 256 is keypad 6
- Location 257 is keypad 7 ➤ Location 258 is keypad 8

Table 26: Keypad Options Data

LED	Default	Action
1	ON	The keypad will timeout back to its default partition after it has been used to view another partition
2	OFF	Keypad sleep mode
3	OFF	Global Keypad Status (Keypad can be moved into any partition to view or control partition)
4	OFF	Display all of Zones from all Partitions
5	OFF	Shows all Partitions on key press 1,5 & 6
6	OFF	Stay Profile Menu
7	OFF	Enable keypad buzzer to follow siren
8	OFF	Global keypad to chime on all partition set chime zones

LED 3 must be ON for LED 1 to have any effect.

The Global Keypad Status will allow sixteen zones to be displayed regardless of the partition to which either the keypad or zones are assigned.

On an LED keypad from the keypad start zone number plus 16 zones.

On an LCD keypad from the keypad start zone number up to 64 zones.

Wireless Integration Options

Wireless integration is tightly integrated into the XSeries alarm panel giving you the best possible reliability from a wireless installation. There are two options to choose from:

1. Xwave which is a single direction communication from the detectors back to a wireless zone receiver, 860-07-563, with supervision and tamper monitoring on the frequency band 433MHz.
2. Xwave² is a bi-directional communication between a transceiver hub and each detector guaranteeing that all signals will get delivered on the frequency band 869MHz.

Both Xwave and Xwave² are programmed in location 260. (See Xwave manual 700-563-02x or Xwave² manual 700-564-01x)

LOCATION 260: Wireless Functions

This location is broken up into different sub locations. Each sub location has a different function.

Sub location 1 learning wireless devices

Sub location 2 deleting wireless devices

Sub location 3 checking signal strength (Xwave only)

Sub location 4 Supervision Time (Xwave only)

Sub location 5 Xwave² Zone Properties

Please see the Xwave, IDS 700-589-02x or Xwave², 700-564-02x manual depending on your installation.

Xwave² associated outputs:

Location 620: Clear Xwave² outputs on disarm

Location 621 – 624: Xwave² outputs pulse time

Location 625 – 628: Xwave² outputs scheduled ON time

Location 629 – 644: Xwave² outputs ON/OFF Days

Location 645 – 648: Xwave² outputs OFF time

Note: Xwave and Xwave² devices that have a **dip switch** selection for **Alarm / Trouble output** should be set to **ON** or **N.O.** for the longest battery life.

Zone Reporting Codes

Contact ID Extended Feature

Locations 304 to 311 when using Contact ID, can send different reporting codes to the control room for violated zones. The table below is a sample of values mapped to Contact ID codes, the complete list is on page 44.

Value	CID	Description
01	100	Medical Zone
02	101	Personal Emergency Zone

Value	CID	Description
3C	303	RAM Checksum bad Zone
3D	304	ROM checksum bad Zone

Example: You have connected a panic button to zone 8, which has a zone type of 3, panic zone for a granny flat and the person has a health issue and may need medical help from time to time. By programming location 304 sub-location 8 with the value 01, when zone 8 is triggered the Contact ID code 100 which is medical zone will be sent to the security company to alert them to send medical help. Please see the appendix for the complete table of values for the Contact ID reporting codes

Note: The following locations valid data ranges are: 01-FF, with 00 to disable. Partition no. is: 1-8.

LOCATIONS 304 – 307 Zone Alarm Reporting Code

The 2-digit zone alarm code is reported when the zone is violated during an arm cycle or if a Panic or 24-Hour zone is violated. Option 1 in Table 37 needs to be enabled.

Each location represents a set of 16 zones:

- Location 304 is zones 1-16
- Location 305 is zones 17-32
- Location 306 is zones 33-48
- Location 307 is zones 39-64

Enter a 2-digit reporting code for each of the 16 zones and program as a 32-digit string, followed by the [*] key.

[INSTALLER CODE] [*] [LOCATION] [*] [ZONE NO.] [*] [REPORTING CODE] [*]

If any of the sub-locations are disabled here, then the reporting codes will not report – even if they are enabled

NOTE: The values are hexadecimal. Refer to **Table 3: Hexadecimal Values** on how to program hexadecimal values.

LOCATIONS 308 – 311 Zone Alarm Restoral Reporting Code

The 2-digit zone restoral code is reported when the zone has returned to the “unviolated” condition after triggering an alarm. Option 2 in Table 37 needs to be enabled.

Each location represents a set of 16 zones:

- Location 308 is zones 1-16
- Location 309 is zones 17-32
- Location 310 is zones 33-48
- Location 311 is zones 39-64

Enter a 2-digit reporting code for each of the 16 zones and program as a 32-digit string, followed by the [*] key.

[INSTALLER CODE] [*] [LOCATION] [*] [ZONE NO.] [*] [REPORTING CODE] [*]

If any of the sub-locations are disabled here, then the reporting codes will not report – even if they are enabled

LOCATIONS 312 – 315 Zone Tamper Reporting Code

The 2-digit tamper code is reported if tamper by zone is enabled and a zone tamper occurs. (Enable Option 5 in Table 37).

Each location represents a set of 16 zones:

- Location 312 is zones 1-16
- Location 313 is zones 17-32
- Location 314 is zones 33-48
- Location 315 is zones 39-64

Enter a 2-digit reporting code for each of the 16 zones and program as a 32-digit string, followed by the [*] key.

[INSTALLER CODE] [*] [LOCATION] [*] [ZONE NO.] [*] [REPORTING CODE] [*]

If any of the sub-locations are disabled here, then the reporting codes will not report – even if enabled at 0

Programmable Outputs

All programmable outputs, PGMs, can be triggered in 4 different ways, see Table 27: Output Actions Data:

Table 27: Output Actions Data

Value	Output Action	Value	Output Action
00	Set Output High (Set)	02	Pulse Output High
01	Set Output Low (Reset)	03	Pulse Output Low

Table 28: Output Address Physical Mapping Data

Addr	Physical Outputs	Addr	Physical Outputs	Addr	Physical Outputs
00	Disabled	20	Output Expander 1 PGM 3	40	Keypad 7
01	Onboard output 1	21	Output Expander 1 PGM 4	41	Keypad 8
02	Onboard output 2	22	Output Expander 1 PGM 5	42	Xwave ² I/O between zones 1 - 4
03	Onboard output 3	23	Output Expander 1 PGM 6	43	Xwave ² I/O between zones 5 - 8
04	Onboard output 4	24	Output Expander 1 PGM 7	44	Xwave ² I/O between zones 9 - 12
05	Onboard output 5	25	Output Expander 1 PGM 8	45	Xwave ² I/O between zones 13 - 16
06	Zone expander 1 PGM 1	26	Output Expander 2 PGM 1	46	Xwave ² I/O between zones 17 – 20
07	Zone expander 1 PGM 2	27	Output Expander 2 PGM 2	47	Xwave ² I/O between zones 21 – 24
08	Zone expander 2 PGM 1	28	Output Expander 2 PGM 3	48	Xwave ² I/O between zones 25 – 28
09	Zone expander 2 PGM 2	29	Output Expander 2 PGM 4	49	Xwave ² I/O between zones 29 – 32
10	Zone expander 3 PGM 1	30	Output Expander 2 PGM 5	50	Xwave ² I/O between zones 33 – 36
11	Zone expander 3 PGM 2	31	Output Expander 2 PGM 6	51	Xwave ² I/O between zones 37 – 40
12	Zone expander 4 PGM 1	32	Output Expander 2 PGM 7	52	Xwave ² I/O between zones 41 – 44
13	Zone expander 4 PGM 2	33	Output Expander 2 PGM 8	53	Xwave ² I/O between zones 45 – 48
14	Zone expander 5 PGM 1	34	Keypad 1	54	Xwave ² I/O between zones 49 – 52
15	Zone expander 5 PGM 2	35	Keypad 2	55	Xwave ² I/O between zones 53 – 56
16	Zone expander 6 PGM 1	36	Keypad 3	56	Xwave ² I/O between zones 57 – 60
17	Zone expander 6 PGM 2	37	Keypad 4	57	Xwave ² I/O between zones 61 - 64
18	Output Expander 1 PGM 1	38	Keypad 5		
19	Output Expander 1 PGM 2	39	Keypad 6		

LOCATION 380 Clear Programmable Onboard Outputs on Disarming

This bitmapped location allows onboard programmable outputs 1-5 to be set low on disarming. The output/s to be cleared will be displayed by zone number LEDs. The programmable outputs will clear when ANY partition is disarmed. Refer to Table 29 to view which zone number LED corresponds to which onboard output.

Table 29: Clear Programmable Onboard Outputs Data

LED	Disarm Clear Output	LED	Disarm Clear Output	LED	Disarm Clear Output
1	Output 1	3	Output 3	5	Output 5
2	Output 2	4	Output 4		

LOCATIONS 381 – 386 Clear Programmable Zone Expander Outputs on Disarming

This bitmapped location allows the 2 outputs of the 6 zone expanders to be set low on disarming. The output(s) to be cleared will be displayed by zone number LEDs. The programmable outputs will clear when ANY partition is disarmed. Refer to Table 30 to view which zone number LED corresponds to which zone expander output.

- Location 381 zone expander 1
- Location 382 zone expander 2
- Location 383 zone expander 3
- Location 384 zone expander 4
- Location 385 zone expander 5
- Location 386 zone expander 6

Table 30: Clear Programmable Zone Expander Outputs Data

LED	Output	LED	Output
1	Output 1	2	Output 2

LOCATION 387 – 388 Clear Programmable Expander Outputs on Disarm

This bitmapped location allows the individual outputs of the output expander to be cleared (set low) on disarming. The output/s to be cleared will be displayed by zone number LEDs. The programmable outputs will clear when ANY partition is disarmed.

Location 387				Location 388			
LED	Output	LED	Output	LED	Output	LED	Output
1	Exp 1 OP 1	5	Exp 1 OP 5	1	Exp 2 OP 1	5	Exp 2 OP 5
2	Exp 1 OP 2	6	Exp 1 OP 6	2	Exp 2 OP 2	6	Exp 2 OP 6
3	Exp 1 OP 3	7	Exp 1 OP 7	3	Exp 2 OP 3	7	Exp 2 OP 7
4	Exp 1 OP 4	8	Exp 1 OP 8	4	Exp 2 OP 4	8	Exp 2 OP 8

Table 31: Clear Programmable Expander Outputs Data

LOCATION 389 Clear Programmable Keypad Outputs on Disarming

This bitmapped location allows the single outputs of the 8 keypads to be cleared (set low) on disarming. The output/s to be cleared will be displayed by zone number LEDs. The programmable outputs will clear when ANY partition is disarmed.

LED	Output	LED	Output	LED	Output	LED	Output
1	Keypad 1	3	Keypad 3	5	Keypad 5	7	Keypad 7
2	Keypad 2	4	Keypad 4	6	Keypad 6	8	Keypad 8

Table 32 to view which zone corresponds to which keypad output.

LED	Output	LED	Output	LED	Output	LED	Output
1	Keypad 1	3	Keypad 3	5	Keypad 5	7	Keypad 7
2	Keypad 2	4	Keypad 4	6	Keypad 6	8	Keypad 8

Table 32: Clear Programmable Keypad Outputs Data

Partition Event Driven Outputs– Advanced

The following locations determine how you assign outputs and output actions to partition events.

LOCATIONS 390 – 414 Partition Programmable Output Events

These locations allow you to configure various programmable output events per partition.

Only one output and action can be assigned per partition, unless otherwise stated. The maximum current available from a programmable output is 100mA.

For zone and keypad events, any zone or keypad assigned to a partition being programmed will trigger an output if that event occurs.

On an LED keypad, LEDs 1-8 represent the output number, and LEDs 9-16 represent the action.

NOTE: Each location has eight sub-locations one for each partition. E.g. sub-location 1 is partition 1, sub-location 2 is partition 2, etc.

Enter a 4-digit value (2 digits as per Table 32 and 2 digits as per table 27) each partition and program as a 32-digit string, followed by the [*] key.

[INSTALLER CODE] [*] [LOCATION] [*] [PARTITION] [*] [OUTPUT] [ACTION] [*]

NOTE: Only an output can be entered for programmable output events 411-414.

Enter a 2-digit value for each partition and program as a 16-digit string, followed by the [*] key.

[INSTALLER CODE] [*] [LOCATION] [*] [PARTITION NO.] [*] [OUTPUT] [*]

A NOTE ON ARM FOLLOWER: If an output which has been set as an Arm Follow Programmable Output will mimic the ARM LED on the keypad. The output will be set High when the partition is armed, set Low when the partition is disarmed, and will flash when the partition has an alarm condition. The benefit of this is that you can attach a Remote Arm/Disarm LED Unit to your Alarm Panel for a visual display of the panel's state.

Table 33: Default Programmable Event Data for locations 390 - 414

Loc	Event	Default Output	Default Action
390	Close Programmable Output Event	Output 3 [03]	Set High [00]
391	Stay Close Programmable Output Event	Disabled [00]	
392	Open Programmable Output Event	Output 3 [03]	Set Low [01]
393	Cancel Restoral Programmable Output Event	Disabled [00]	
394	Alarm Restoral Programmable Output Event	Disabled [00]	
395	Bypass Programmable Output Event	Disabled [00]	
396	Forced Arm Programmable Output Event	Disabled [00]	
397	Zone Tamper Programmable Output Event	Disabled [00]	
398	Zone Tamper Restoral Programmable Output Event	Disabled [00]	
399	Zone Shutdown Programmable Output Event	Disabled [00]	
400	Zone Shutdown Restoral Programmable Output Event	Disabled [00]	
401	Keypad Panic Programmable Output Event	Output 1 [01]	Pulse High [02]
402	Keypad Fire Programmable Output Event	Output 4 [04]	Pulse High [02]
403	Keypad Medical Programmable Output Event	Output 5 [05]	Pulse High [02]
404	Keypad Lockout Programmable Output Event	Disabled [00]	
405	Duress Programmable Output Event	Output 1 [01]	Pulse High [02]
406	Verifies Alarm Programmable Output Event	Disabled [00]	
407	Burglary Programmable Output Event	Output 2 [02]	Pulse High [02]
408	Panic Programmable Output Event	Output 1 [01]	Pulse High [02]
409	Fire Programmable Output Event (Refer to Table 5 page 15)	Output 4 [04]	Pulse High [02]
410	Tamper Zone Programmable Output Event	Disabled [00]	

Table 34: Default Programmable Events Data with no Default Action

Loc	Event	Default Output
411	Siren Programmable Output Event	Disabled [00]
412	Strobe Programmable Output Event	Disabled [00]
413	Chime Programmable Output Event	Disabled [00]
414	Arm Follow Programmable Output Event	Disabled [00]

NOTE: Once a programmable output has been enabled, the default action will be Pulse High [02].

Zone Programmable Output Events

The following locations are used to program the various zone outputs.

LOCATIONS 415 – 422 Zone Programmable Output Events

An output can be assigned to a zone so when the zone causes an alarm condition or if trigger zone if violated, option 7 in location 101-164 has been enabled, the chosen output performs the selected option. A list of available actions and their corresponding values are shown in Table 27.

Regardless of the action selected for an output, if it is programmed to clear on disarming of the panel (locations 380-389), the output will revert to clear (set low) after any partition disarmed.

Each location represents a set of 8 zones:

- | | | |
|----------------------------|--------------------------------|----------------------------|
| ➤ Location 415 zones 1-8 | ➤ Location 416 zones 9-16 | ➤ Location 417 zones 17-24 |
| ➤ Location 418 zones 25-32 | ➤ Location 419 are zones 33-40 | ➤ Location 420 zones 41-48 |
| ➤ Location 421 zones 49-56 | ➤ Location 422 zones 57-64 | |

Enter a 4-digit output and action for each of the 8 zones and program as 32-digit strings, followed by the [*] key.

[INSTALLER CODE] [*] [4] [1] [5] [*] [ZONE NO.] [*] [OUTPUT] [ACTION] [*]

LOCATIONS 423 – 427 Global Programmable Output Events

These locations allow you to configure the global programmable output events. Refer to Table 35 to view the programmable output events per location.

- LEDs 1-8 represent the output number, and LEDs 9-16 represent the action. Once a programmable output has been enabled, the default action will be Pulse High [02].
- There is no output action for the fire sensor power programmable output events.

Table 35: Global Programmable Output Events Default Data

Loc	Sub-loc	Event	Default Output	Default Action
423	1	Mains Fail Programmable Output Event	Disabled [00]	
	2	Mains Restore Programmable Output Event	Disabled [00]	
	3	Low Battery Programmable Output Event	Disabled [00]	
	4	Low Battery Restore Programmable Output Event	Disabled [00]	
	5	Auto Test Programmable Output Event	Disabled [00]	
	6	Download Programmable Output Event	Disabled [00]	
	7	Siren Tamper Programmable Output Event	Disabled [00]	
	8	Aux 12V Trouble Programmable Output Event	Disabled [00]	
424	1	Reserved	Disabled [00]	
424	2	Bus-wired Peripheral Tamper Programmable Output Event	Disabled [00]	
	3	Bus-wired Peripheral Fail Programmable Output Event	Disabled [00]	
	4	Box Tamper Programmable Output Event	Disabled [00]	
	5	Dedicated Panic Programmable Output Event	Output [01]	Pulse High[02]
	6	Communication Fail Programmable Output Event	Disabled [00]	
	7	Telephone Line Tamper Programmable Output Event	Disabled [00]	
	8	Telephone Line Restore Programmable Output Event	Disabled [00]	
	425	1	RF JAM	Disabled [00]
2		RF JAM Reset	Disabled [00]	
3		RF Supervision Fail	Disabled [00]	
4		RF Detector Battery Low	Disabled [00]	
5		RF Detector Battery Restore	Disabled [00]	
6		RF Receiver Battery Low	Disabled [00]	
7		RF Receiver Battery Low	Disabled [00]	
426	1	Wired Zone Expander Low Battery Programmable Output Event	Disabled [00]	
	2	Wired Zone Expander Low Battery Restore Programmable Output Event	Disabled [00]	
	3	Fire Sensor Power Programmable Output Event	Disabled [00]	No Action
	4	Reserved		
	5	AC Fail Monitored Power Supply Unit	Disabled [00]	
	6	AC Restore Monitored Power Supply Unit	Disabled [00]	
	7	Low Battery Monitored Power Supply Unit	Disabled [00]	

Loc	Sub-loc	Event	Default Output	Default Action
	8	Battery Restore Monitored Power Supply Unit	Disabled [00]	
427	1	Fuse fail on monitored power supply	Disabled [00]	
	2	Fuse restore on monitored power supply	Disabled [00]	

Enter a 4-digit value (2 digits as per Table 32 and 2 digits as per table 27) each partition and program as a 32-digit string, followed by the [*] key.

[INSTALLER CODE] [*] [LOCATION] [*] [SUB-LOCATION] [*] [OUTPUT] [ACTION] [*]

NOTE: Once a programmable output has been enabled, the default action will be Pulse High [02].

Output Pulse Timing - Advanced

The following locations determine the length of time for which an output will pulse high before returning to a clear state.

LOCATION 428 Onboard Output Pulse Time (default = 0002)

Enter a 4-digit time, [MMSS], for each of the 5 onboard outputs and program as a 20-digit string, followed by the [*] key.

[INSTALLER CODE] [*] [4] [2] [8] [*] [OUTPUT NO.] [*] [MMSS] [*]

The valid data range is: 00m00s – 59m59s. Output no. is: 1-5.

LOCATION 429 – 434 Zone Expander Output Pulse Time (default = 0002)

Enter a 4-digit time, [MMSS], for each of the 6 zone expanders output and program as an 8-digit string, followed by the [*] key.

[INSTALLER CODE] [*] [LOCATION] [*] [OUTPUT NO.] [*] [MMSS] [*]

The valid data range is: 00m00s – 59m59s. Output no. is: 1-2.

LOCATION 435 – 436 Output Expander Programmable Output Pulse Time (default = 0002)

Enter a 4-digit time, [MMSS], for each of the 8 outputs on each output expander and program as a 32-digit string, followed by the [*] key.

[INSTALLER CODE] [*] [LOCATION] [*] [OUTPUT NO.] [*] [MMSS] [*]

The valid data range is: 00m00s – 59m59s. Output no. is: 1-8.

LOCATION 437 Keypad Output Pulse Time (default = 0002)

Enter a 4-digit time, [MMSS], for each of the 8 keypads output and program as a 32-digit string, followed by the [*] key.

[INSTALLER CODE] [*] [4] [3] [7] [*] [OUTPUT NO.] [*] [MMSS] [*]

The valid data range is: 00m00s – 59m59s. Output no. is: 1-8.

Output Scheduling On Time - Advanced

The following locations determine the time of day for each of the programmable outputs to turn on/off. These outputs can either be set high (on) or low (off). For the following locations to work the appropriate on/off days (locations 458-498), must be selected.

LOCATION 438 Onboard Output ON Time (default = 2400)

Enter a 4-digit time, [HHMM], for each of the 5 onboard outputs and program as a 20-digit string, followed by the [*] key.

[INSTALLER CODE] [*] [4] [3] [8] [*] [OUTPUT NO.] [*] [HHMM] [*]

The valid data range is: 00h00m – 23h59m, with 24h00m to disable. Output no. is: 1-5.

LOCATION 439 – 444 Zone Expander Output ON Time (default = 2400)

Enter a 4-digit time, [HHMM], for each of the 6 zone expanders output and program as an 8-digit string, followed by the [*] key.

[INSTALLER CODE] [*] [LOCATION] [*] [OUTPUT NO.] [*] [HHMM] [*]

The valid data range is: 00h00m – 23h59m, with 24h00m to disable. Output no. is: 1-2.

LOCATION 445 – 446 Output Expander ON Time (default = 2400)

Enter a 4-digit time, [HHMM], for each of the 8 outputs on the output expanders and program as a 32-digit string, followed by the [*] key.

[INSTALLER CODE] [*] [LOCATION] [*] [OUTPUT NO.] [*] [HHMM] [*]

The valid data range is: 00h00m – 23h59m, with 24h00m to disable. Output no. is: 1-8.

LOCATION 447 Keypad Output ON Time (default = 2400)

Enter a 4-digit time, [HHMM], for each of the 8 keypads output and program as a 32-digit string, followed by the [*] key.

[INSTALLER CODE] [*] [4] [4] [7] [*] [OUTPUT NO.] [*] [HHMM] [*]

The valid data range is: 00h00m – 23h59m, with 24h00m to disable. Output no. is: 1-8.

Output Scheduling Off Time - Advanced

The following locations determine the programmed time for the programmable output to turn off. These outputs can either be set high (on) or low (off). For the following locations to work the appropriate on/off days (locations 458-498), must be selected.

LOCATION 448 Onboard Output OFF Time (default = 2400)

Enter a 4-digit time, [HHMM], for each of the 5 onboard outputs and program as a 20-digit string, followed by the [*] key.

[INSTALLER CODE] [*] [4] [8] [*] [OUTPUT NO.] [*] [HHMM] [*]

The valid data range is: 00h00m – 23h59m, with 24h00m to disable. Output no. is: 1-5.

LOCATION 449 – 454 Zone Expander Output OFF Time (default = 2400)

Enter a 4-digit time, [HHMM], for each of the 6 zone expander outputs and program as an 8-digit string, followed by [*] key.

[INSTALLER CODE] [*] [LOCATION] [*] [OUTPUT NO.] [*] [HHMM] [*]

The valid data range is: 00h00m – 23h59m, with 24h00m to disable. Output no. is: 1-2.

LOCATION 455 – 456 Output Expander Output OFF Time (default = 2400)

Enter a 4-digit time, [HHMM], for each of the 8 outputs on the output expander and program as a 32-digit string, followed by the [*] key.

[INSTALLER CODE] [*] [LOCATION] [*] [OUTPUT NO.] [*] [HHMM] [*]

The valid data range is: 00h00m – 23h59m, with 24h00m to disable. Output no. is: 1-8.

LOCATION 457 Keypad Output OFF Time (default = 2400)

Enter a 4-digit time, [HHMM], for each of the 8 keypad outputs and program as a 32-digit string, followed by the [*] key.

[INSTALLER CODE] [*] [4] [5] [7] [*] [OUTPUT NO.] [*] [HHMM] [*]

The valid data range is: 00h00m – 23h59m, with 24h00m to disable. Output no. is: 1-8.

Output Scheduling On/Off Days - Advanced

Outputs can be scheduled to set and reset at specified times on specific days of the week. To disable scheduling of an output, ensure that all “days” are deselected.

LOCATIONS 458 – 498 Output On/Off Days

The on/off days for the outputs, to turn on or off, in Table 40 can be programmed by using the values in Table 36.

Table 36: Output Scheduling On/Off Days Data

LED	ON Days of the Week
1	Monday
2	Tuesday
3	Wednesday
4	Thursday
5	Friday
6	Saturday
7	Sunday
All OFF	(Arm Day Disabled)

LED	OFF Days of the Week
9	Monday
10	Tuesday
11	Wednesday
12	Thursday
13	Friday
14	Saturday
15	Sunday
All OFF	(Disarm Day Disabled)

Enable or Disable of Event Reporting Options - Advanced

Locations 501 to 588 have options that are enable or disable, with default values in the column titled 'Default'.

Options 1 – 8: ON = Enable OFF = Disable

LOCATIONS 501 – 564 Enable or Disable Zone Reporting (Zones 1 – 64)

Locations 501 (zone 1) – 564 (zone 64) represent a bitmap of 64 reporting zone locations.

Table 37: Reporting Zones Bitmap Data

LED	Default	Action
1	ON	Zone alarm reporting
2	OFF	Zone alarm restore reporting
3	OFF	Zone bypass reporting
4	OFF	Zone force arm reporting
5	OFF	Zone tamper reporting
6	OFF	Zone tamper restore reporting
7	OFF	Zone swinger shutdown reporting
8	OFF	Zone swinger shutdown restore reporting

LOCATION 571 Enable or Disable Global Reporting 1

Table 38: Global Reporting 1 Bitmap Data

LED	Default	Action
1	ON	Mains fail reporting
2	OFF	Communication fail reporting *
3	ON	Telephone line tamper reporting
4	ON	Siren fail reporting
5	ON	Panel low battery fail reporting
6	ON	Aux 12V fuse fail reporting
7	OFF	Installer Reset Required
8	ON	Box tamper reporting

LOCATION 572 Enable or Disable Global Reporting 2

Table 39: Global Reporting 2 Bitmap Data

LED	Default	Action
1	ON	Bus-wired peripheral tamper reporting
2	ON	Bus-wired peripheral fail reporting
3	OFF	Bus-wired peripheral low battery reporting *
4	ON	Wireless Detector Battery Low
5	ON	Wireless Detector Supervision fail
6	OFF	Wireless Receiver Signal Jammed
7	OFF	Wireless Detector RSSI Low
8	ON	Mains Restored

LOCATION 573 Enable or Disable Global Reporting 3

Table 40: Global Reporting 3 Bitmap Data

LED	Default	Action
1	OFF	Comms Restored
2	OFF	Comms Tamper Restore
3	OFF	Siren Restore
4	ON	Battery Restore
5	OFF	Aux 12V Restored
6	OFF	Installer Reset restored
7	OFF	Box tamper restored
8	OFF	Bus device tamper restored

LOCATION 574 Enable or Disable Global Reporting 4**Table 41: Global Reporting 4 Bitmap Data**

LED	On/Off	Action
1	OFF	Bus device comms restored
2	OFF	Bus device battery restored
3	ON	Wireless Detector Battery restored
4	ON	Wireless Detector Supervision restored
5	OFF	Wireless Receiver Jam restored
6	OFF	Wireless Detector RSSI low restored
7	ON	Dedicated Panic
8	ON	Test Report

LOCATION 575 Global Reporting 5**Table 42: Global Reporting 5 Bitmap Data**

LED	Default	Action
1	OFF	IDSift Download Accessed
2	OFF	AC Fail Monitored PSU
3	OFF	AC Restore Monitored PSU
4	OFF	Low Battery Monitored PSU
5	OFF	Battery Restore Monitored PSU
6	OFF	Fuse Blown Monitored PSU
7	OFF	Fuse Restore Monitored PSU

LOCATIONS 581 – 588 Enable or Disable Reporting Partitions 1-8 (Partition 1 = 581, Partition 2 = 582.....)**Table 43: Reporting Partitions 1-8 Data**

LED	Default	Action
1	ON	Duress reporting
2	ON	Keypad panic reporting
3	ON	Fire reporting
4	ON	Medical reporting
5	ON	Keypad lockout reporting
6	OFF	Reserved
7	OFF	Armed without user code reporting
8	OFF	Reserved

9. Touch Keypad Switch to Programmable Output Mapping

Location 649 Switch to PGM Mapping

NOTE: This function is only available in XSeries firmware version 2.80 and upwards and if an IDS touch keypad (860-03-613) is connected!

In location 649 any nine outputs that are available on the XSeries can be mapped to switches 1 to 9. E.g.: If a spotlight has been connected to output 5. Output 5 can be mapped to switch 1, so that when the switch key is pressed and switch 1 is selected the output will trigger either as a pulse or toggle depending on the selected action in location 650.

[INSTALLER CODE] [*] [6] [4] [9] [*] [Switch NO.] [*] [Output No.] [*]

The valid data range: Switch No. 1 – 9, Outputs 1 – 41.

Location 650 Selecting Switch Toggle or Pulse Action

When using the switch function on the IDS touch keypad and programmable outputs have been mapped to switches 1 – 9, an action must be selected for each switch mapped to an output.

[INSTALLER CODE] [*] [6] [5] [0] [*] [Switch NO.] [*] [*]

Selection	Function	Description
N	Toggle	When the switch is selected the output will toggle its state. E.g. If the output was off it will toggle on and remain on until someone selects that switch again.
Y	Pulse	When the switch that is configured to pulse is selected the output will change state for 3 seconds and then return to its previous state. E.g. If the output was off it will switch on and 3 seconds later switch off.

NOTE: Switches can be named with more user-friendly names, E.g. 'Switch 1' can be named to 'Gate'. Please see the XSeries User Manual for version 2.80 and up or the IDS touch keypad Manual.

10. Xwave² Outputs

Xwave² output locations:

Location 620 Clear Xwave² outputs on disarm

Location 621 - 624 Xwave² outputs pulse time

Location 625 - 628 Xwave² outputs scheduled ON time

Location 629 - 644 Xwave² outputs ON/OFF Days

Location 645 - 648 Xwave² outputs OFF time

See Table 32: Output Address Physical Mapping Data for Xwave² output numbering.

Please see the Xwave² manual, 700-564-04x, for detailed programming instructions.

11. LCD Keypad Information

[1] and [3]

To view information for an individual keypad, press the [1] and [3] keys simultaneously and then quickly release.

The LCD keypad will display 'Keypad Info'. Use the [PANIC] and [MED] keys to scroll through the available information.

- Lowest Zone This displays the start zone of the keypad (this is only applicable to LED keypad; therefore, the LCD keypad will always display 01)
- Highest Zone This displays the end zone of the keypad (this is only applicable to the LED keypad; therefore, the LCD keypad will always display 64)
- Zone Mask This displays the zones. The information is read from right to left. Each hex character displays information for 4 zones
- Version Nr This displays the version number of the keypad firmware
- Version Date This displays the date the version was created

When phoning the helpdesk for technical support, it is important to be able to give them the firmware version of the keypad. This will help with the troubleshooting process.

12. Panel Information

[*][*]

To view information, using a LCD keypad, for the panel, hold down the [*] key to enter the user menu, then press the [*] key again to enter into the panel information.

Use the [*] key to scroll through the information.

- > FW This displays the firmware version of the panel
- > HW This displays the hardware version of the panel
- > BL This displays the boot loader version of the panel
- > BN This displays the build number of the panel

When phoning the helpdesk for technical support, it is important to be able to give them all (or at least) some of information for the panel. This will help with the troubleshooting process.

13. User Options

1. "Auto Test" option 97
2. New Partition Menu on LCD keypads
 - a. When entering quick arm, stay arm or stay go and the option is enabled all partitions will be shown with their status
 - b. Menu status options:
 - i. r = ready
 - ii. n = not ready
 - iii. E = entry/exit delay
 - iv. S = stay armed
 - v. A = away armed
 - vi. ! = alarm
3. Slot 1 Master code can add codes to all partitions.
 - a. Slot 2 to 128 can only add codes to their allocated partition
4. Manual PGM mode can be done even if keypad is in armed state
5. Panic zones can be bypassed if enabled in zone options location 101 to 164
6. New User Property -- Allow or disallow a user from bypassing zones (Option 10)

Partitions



Status



1 2 3 4 5 6 7 8
r n E S A ! n r

Extra Contact ID Zone Reporting Codes

When these values are entered into locations 304 to 307 the zone that now has this new value will report the Contact ID code that is associated with it.

Table 44: Extra Zone CID Reporting Codes

Value	CID	Description
01	100	Medical Zone
02	101	Personal Emergency Zone
03	102	Fail to report in Zone
04	110	Fire Zone
05	111	Smoke Zone
06	112	Combustion Zone
07	113	Water flow Zone
08	114	Heat Zone
09	115	Pull Station Zone
0A	116	Duct Zone
0B	117	Flame Zone
0C	118	Near Alarm Zone
0D	120	Panic Zone
0E	121	Duress User
0F	122	Silent Zone
10	123	Audible Zone
11	124	Duress – Access granted Zone
12	125	Duress – Egress granted Zone
13	130	Burglary Zone
14	131	Perimeter Zone
15	132	Interior Zone
16	133	24 Hour (Safe) Zone
17	134	Entry/Exit Zone
18	135	Day/night Zone
19	136	Outdoor Zone
1A	137	Tamper Zone
1B	138	Near alarm Zone
1C	139	Intrusion Verifier Zone
1D	140	General Alarm Zone
1E	141	Polling loop open Zone
1F	142	Polling loop short Zone
20	143	Expansion module failure Zone
21	144	Sensor tamper Zone
22	145	Expansion module tamper Zone
23	146	Silent Burglary Zone
24	147	Sensor Supervision Failure Zone
25	150	24 Hour Non-Burglary Zone
26	151	Gas detected Zone
27	152	Refrigeration Zone
28	153	Loss of heat Zone
29	154	Water Leakage Zone
2A	155	Foil Break Zone
2B	156	Day Trouble Zone
2C	157	Low bottled gas level Zone
2D	158	High temp Zone
2E	159	Low temp Zone
2F	161	Loss of air flow Zone

Value	CID	Description
3C	303	RAM Checksum bad Zone
3D	304	ROM checksum bad Zone
3E	305	System reset Zone
3F	306	Panel programming changed Zone
40	307	Self- test failure Zone
41	308	System shutdown Zone
42	309	Battery test failure Zone
43	310	Ground fault Zone
44	311	Battery Missing/Dead Zone
45	312	Power Supply Overcurrent Zone
46	313	Engineer Reset User
47	320	Sounder/Relay Zone
48	321	Bell 1 Zone
49	322	Bell 2 Zone
4A	323	Alarm relay Zone
4B	324	Trouble relay Zone
4C	325	Reversing relay Zone
4D	326	Notification Appliance Ckt. # 3 Zone
4E	327	Notification Appliance Ckt. #4 Zone
4F	330	System Peripheral trouble Zone
50	331	Polling loop open Zone
51	332	Polling loop short Zone
52	333	Expansion module failure Zone
53	334	Repeater failure Zone
54	335	Local printer out of paper Zone
55	336	Local printer failure Zone
56	337	Exp. Module DC Loss Zone
57	338	Exp. Module Low Batt. Zone
58	339	Exp. Module Reset Zone
59	341	Exp. Module Tamper Zone
5A	342	Exp. Module AC Loss Zone
5B	343	Exp. Module self-test fail Zone
5C	344	RF Receiver Jam Detect Zone
5D	350	Communication trouble Zone
5E	351	Telco 1 fault Zone
5F	352	Telco 2 fault Zone
60	353	Long Range Radio Transmitter Fault Zone
61	354	Failure to communicate event Zone
62	355	Loss of Radio supervision Zone
63	356	Loss of central polling Zone
64	357	Long Range Radio VSWR problem Zone
65	370	Protection loop Zone
66	371	Protection loop open Zone
67	372	Protection loop short Zone
68	373	Fire trouble Zone
69	374	Exit error alarm (zone) Zone
6A	375	Panic zone trouble Zone

Value	CID	Description
30	162	Carbon Monoxide detected Zone
31	163	Tank level Zone
32	200	Fire Supervisory Zone
33	201	Low water pressure Zone
34	202	Low CO2 Zone
35	203	Gate valve sensor Zone
36	204	Low water level Zone
37	205	Pump activated Zone
38	206	Pump failure Zone
39	300	System Trouble Zone
3A	301	AC Loss Zone
3B	302	Low system battery Zone
77	389	Sensor self-test failure Zone
78	391	Sensor Watch trouble Zone
79	392	Drift Compensation Error Zone
7A	393	Maintenance Alert Zone
7B	400	Open/Close User
7C	401	O/C by User
7D	402	Group O/C User
7E	403	Automatic O/C User
7F	404	Late to O/C (Note: use 453, 454 instead) User
80	405	Deferred O/C (Obsolete-do not use)
81	406	Cancel User
82	407	Remote arm/disarm User
83	408	Quick arm User
84	409	Key switch O/C User
85	441	Armed STAY User
86	442	Key switch Armed STAY User
87	450	Exception O/C User
88	451	Early O/C User
89	452	Late O/C User
8A	453	Failed to Open User
8B	454	Failed to Close User
8C	455	Auto-arm Failed User
8D	456	Partial Arm User
8E	457	Exit Error (user) User
8F	458	User on Premises User
90	459	Recent Close User
91	461	Wrong Code Entry Zone
92	462	Legal Code Entry User
93	463	Re-arm after Alarm User
94	464	Auto-arm Time Extended User
95	465	Panic Alarm Reset Zone
96	466	Service On/Off Premises User
97	411	Call back request made User
98	412	Successful download/access User
99	413	Unsuccessful access User
9A	414	System shutdown command received User
9B	415	Dialler shutdown command received User
9C	416	Successful Upload Zone
9D	421	Access denied User
9E	422	Access report by user

Value	CID	Description
6B	376	Hold-up zone trouble Zone
6C	377	Swinger Trouble Zone
6D	378	Cross-zone Trouble Zone
6E	380	Sensor trouble Zone
6F	381	Loss of supervision - RF Zone
70	382	Loss of supervision - RPM Zone
71	383	Sensor tamper Zone
72	384	RF low battery Zone
73	385	Smoke detector Hi sensitivity Zone
74	386	Smoke detector Low sensitivity Zone
75	387	Intrusion detector Hi sensitivity Zone
76	388	Intrusion detector low sensitivity Zone
AD	521	Bell 1 disable Zone
AE	522	Bell 2 disable Zone
AF	523	Alarm relay disable Zone
B0	524	Trouble relay disable Zone
B1	525	Reversing relay disable Zone
B2	526	Notification Appliance Ckt. # 3 disable Zone
B3	527	Notification Appliance Ckt. # 4 disable Zone
B4	531	Module Added Zone
B5	532	Module Removed Zone
B6	551	Dialler disabled Zone
B7	552	Radio transmitter disabled Zone
B8	553	Remote Upload/Download disabled Zone
B9	570	Zone/Sensor bypass Zone
BA	571	Fire bypass Zone
BB	572	24 Hour zone bypass Zone
BC	573	Burg. Bypass Zone
BD	574	Group bypass User
BE	575	Swinger bypass Zone
BF	576	Access zone shunt Zone
C0	577	Access point bypass Zone
C1	601	Manual trigger test report Zone
C2	602	Periodic test report Zone
C3	603	Periodic RF transmission Zone
C4	604	Fire test User
C5	605	Status report to follow Zone
C6	606	Listen- in to follow Zone
C7	607	Walk test mode User
C8	608	Periodic test - System Trouble Present Zone
C9	609	Video Transmitter active Zone
CA	611	Point tested OK Zone
CB	612	Point not tested Zone
CC	613	Intrusion Zone Walk Tested Zone
CD	614	Fire Zone Walk Tested Zone
CE	615	Panic Zone Walk Tested Zone
CF	616	Service Request Zone
D0	621	Event Log reset Zone
D1	622	Event Log 50% full Zone
D2	623	Event Log 90% full Zone
D3	624	Event Log overflow Zone
D4	625	Time/Date reset User

Value	CID	Description
9F	423	Forced Access Zone
A0	424	Egress Denied User
A1	425	Egress Granted User
A2	426	Access Door propped open Zone
A3	427	Access Door Status Monitor Trouble Zone
A4	428	Access point Request to Exit trouble Zone
A5	429	Access program mode entry User
A6	430	Access program mode exit User
A7	431	Access threat level change User
A8	432	Access relay/trigger fail Zone
A9	433	Access RTE shunt Zone
AA	434	Access DSM shunt Zone
AB	501	Access reader disable Zone
AC	520	Sounder/Relay Disable Zone

Value	CID	Description
D5	626	Time/Date inaccurate Zone
D6	627	Program mode entry Zone
D7	628	Program mode exit Zone
D8	629	32 Hour Event log marker Zone
D9	630	Schedule change Zone
DA	631	Exception schedule change Zone
DB	632	Access schedule change Zone
DC	641	Senior Watch Trouble Zone
DD	642	Latch-key Supervision User
DE	651	Reserved for Ademco Use Zone
DF	652	Reserved for Ademco Use User
E0	653	Reserved for Ademco Use User
E1	654	System Inactivity

15. Trouble Display

A trouble condition is indicated by the power LED on the keypad flashing.

To view what the trouble condition, hold the 7 key for 3 seconds.

To cancel the trouble condition, once it has been rectified, go into viewing the trouble condition and then press #. LED/LCD viewable trouble conditions

No.	Trouble	Description
1	Mains Fail	24V Mains has gone missing
2	Communication Failed	The alarm has tried to communicate with the reporting device and failed
3	Phone line tamper	The system has detected that the phone line is not connected
4	Siren tamper	The system has detected that the siren is no longer connected
5	Battery Trouble	The battery has been removed or is faulty
6	AUX 12V trouble	The fuse is faulty, or a device is causing a power issue
7	Engineer reset	Enter the installer code before the system will arm.
8	Box Trouble	The box tamper has been violated
9	Bus device tamper	A device connected to the keypad bus has been tampered
10	Bus device communication	A device connected to the keypad bus has lost communication with the system
11	Bus device power	A device connected to the keypad bus has lost power
12	Wireless detector battery low	A wireless detector's battery is low and must be replaced
13	Wireless detector supervision failure	Communication to a wireless detector has gone missing
14	Wireless receiver jam	Wireless receiver has detected a signal that is causing it to lose communication with all devices
15	Wireless detector RSSI trouble	The signal being received from a detector is too low
16	Zone Tamper	A zone has experienced a tamper

Extra trouble conditions viewable only with a LCD keypad.

Trouble	Description
AC fail monitored power supply	The power supply being monitored by a zone expander has experienced a power failure and is drawing power from the battery
Low battery monitored power supply	The power supply being monitored by a zone expander has experienced a power failure and is drawing power from the battery, but the battery is low and will not be able to continue supplying power
Blown fuse on the monitored power supply	The fuse protecting the battery has blown and needs to be replaced

Index

24 Hour Alarm Zone	16	Mains Failure.....	9, 19
AC Fail / Restore Reporting Delay	19	Number of Account Code Digits	22
Arm		Number of Dial Attempts	24
Stay	26	Outdoor Instant Zone.....	16
Arm/Disarm Zone.....	16	Panic/Priority Zone	16
Auto Arm Days	28	Partition Options.....	31
Auto Disarm Time	29	Peripheral Devices	9
Battery	18, 20	Primary Entry Delay Period	31
Bitmapped Location.....	13, 14	Primary Entry/Exit Zone	16, 31
Box Tamper.....	9, 37, 40	Programmable Outputs.....	9, 35, 37
Cross-zone Delay Timer.....	18, 26	Programming a Bitmapped Location	14
Cross-zoning.....	26	Programming Extended Locations.....	14
Damaged Keypad	10	Programming Location Summary	15
Default Keypad Partition	31	Programming Standard Locations	14
Defaulting Keypads	11	Quick Arm (Explanation)	30
Devices (Enrolling)	10	Radio Transmitter Connection	9
Disabled Zone	16	Remote Control Receiver	9
Download Code.....	12	Remote Control Unit	9, 16
Download Software	11	Remote Receiver	9, 10
End-of-Line Resistors	9	Replacing a Damaged Keypad Device.....	10
Engineer Reset (Explanation)	30	resistors	9
Enrolling Keypads.....	10	Secondary Entry/Exit Zone.....	16
Entering Program Mode.....	14	Silent Zone	26
Entry Delay.....	26	Siren.....	19, 26
Event Log	10, 11, 16, 24	Siren Toot on Away Arm / Disarm (Explanation)	30
Exit Delay	26	Stay Mode.....	26
Expander Module - Installation	9	Stay Profile.....	26
Fire Zone.....	16, 21, 26	Stay Zone	<i>See Zone</i>
Follower Zone	16	Swinger Shutdown	26
Force Arm (Explanation)	30	Tamper.....	20
Global Options	21	Tamper by Zone	26, 34
Hardware Default Switch	10	Tamper Zone.....	16
Installer Code.....	11, 22, 29	Touch Keypad Switch to Programmable Output	
Instant Zone.....	16	Mapping.....	42
Keypad Bus	9, 10	Transformer	9
Keypad Lockout Count	21	Warning Zone.....	16
Keypad Options	32	Wiring	10
Keypad Setup (Individual)	32	Zone	
Key-switch.....	9, 16, 30	Buzz	26
Location Values.....	12	Entry/Exit.....	26
locations	15	Stay.....	26
Locations.....	15	Zone Properties.....	26
log <i>See</i> Event Log			



Inhep Electronics Holdings (Pty)Ltd guarantees all IDS control panels against defective parts and workmanship for 24 months from date of purchase. Inhep Electronics Holdings shall, at its option, repair or replace the defective equipment upon return of such equipment to any Inhep Electronics Holdings branch. This warranty applies ONLY to defects in components and workmanship and NOT to damage due to causes beyond the control of Inhep Electronics Holdings, such as incorrect voltage, lightening damage, mechanical shock, water damage, fire damage, or damage arising out of abuse and improper application of the equipment.

NOTE: Wherever possible, return only the PCB to Inhep Electronics Holdings as it is not necessary to return the enclosure for electronic swap outs.

The XSeries product is a product of IDS (Inhep Digital Security) and is manufactured by Inhep Electronics Holdings (Pty) Ltd.

WARNING

For safety reasons, only connect equipment with a telecommunications compliance label. This includes customer equipment previously labelled permitted or certified.

This is a professional product, and due to the nature of the product, should only be installed by an accredited professional alarm installer.

Helpdesk Number: 0860705137 **

**Please note this is NOT a toll-free number

