

# ENSA<sup>TM</sup>

Energy Saving Devices

## LOL-A16-WS2

### INTELLIGENT LED OYSTER LIGHT



**INSTRUCTION MANUAL**

[www.ensalife.com](http://www.ensalife.com)



Thank you for purchasing an LOL-A16-WS2 Intelligent LED Oyster Light.

The ENSA LED oyster light features a robust weather and vandal resistant housing making it ideal for outdoor and indoor use. Available in cool and warm white colour temperatures, these oyster lights utilise the latest LED technology to provide evenly dispersed, low glare lighting with at least 75lm/W luminous efficacy and up to 30,000 hours rated lifespan.

**For installation by a qualified electrician only.**

**FUNCTION:**

- The intelligent light can sense day & night, functioning differently daytime and nighttime (Daylight Sensor). Daylight sensor and light settings can be adjusted via DIP switch.
- On-Time Delay is optional, ranging from 10sec to 10min.
- Offers 3 levels of light: 100%, dimmed light (10% or 20% optional) & off; with 2 periods of selectable waiting time, On-Time Delay and Stand-by Period; adjustable lux levels value & detection adjustment.

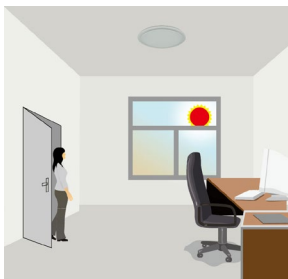

With ambient light more than daylight threshold, the lamp does not switch on when someone enters the room

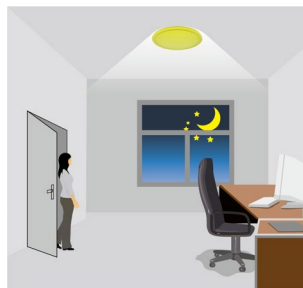

With ambient light less than daylight threshold, the lamp will be on 100% when someone enters the room

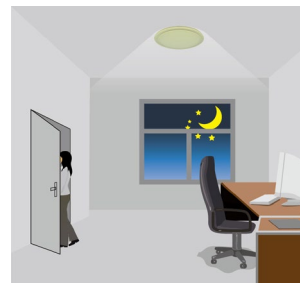

People left, light dims to 10% or 20% (optional) stand-by level after hold time

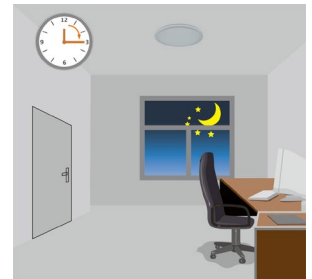

Light switches off automatically after the stand-by period elapsed

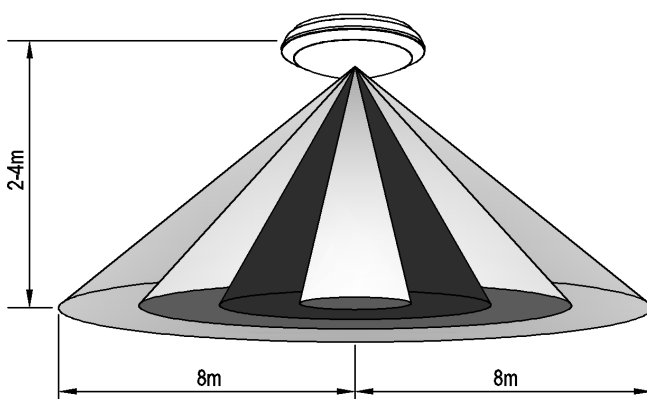

Height of installation: 2-4m

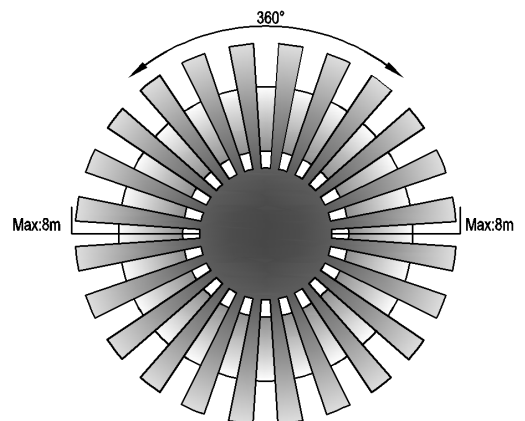

Detection Area: Max. 8m (radius)

**INSTALLATION:** (see the diagram)

- Switch off the power.
- Rotate the plastic clockwise to open, screw off the screws on the lampshade to open.
- Insert wire through the holes provided and connect according to connect-wire diagram.
- Fix the metal bracket base on the ceiling through the holes on base pan with screws provided.
- Switch on the power to test.

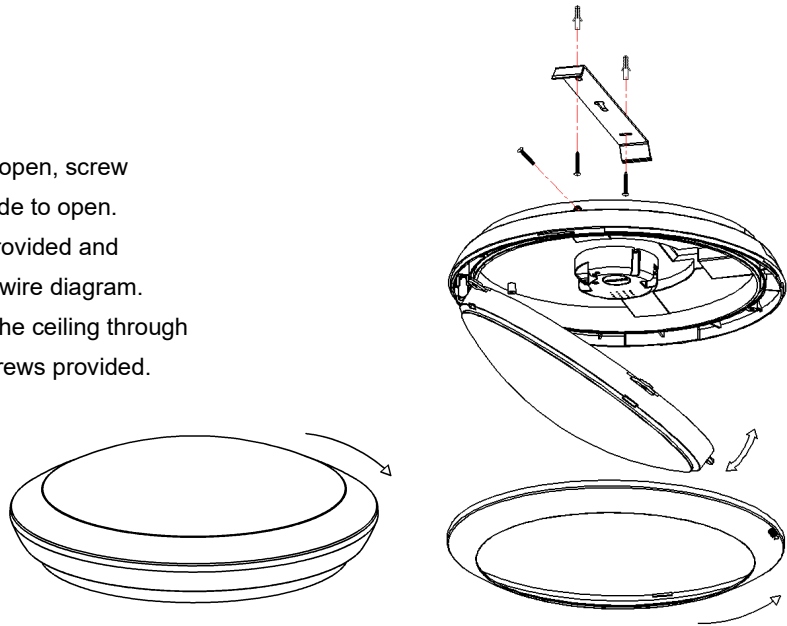

**SETTINGS:**

**Detection Range – 1**

DIP switches 1 adjusts the maximum motion detection range, as specified on the table to the right.



1	
●	100%
○	50%

**On-Time Delay – 2 & 3**

Adjusts the period of time after motion is detected that the light stays at 100% brightness. After the On-Time Delay has elapsed, the light switches to Sensing Mode.



2	3	
●	●	10S
○	●	90S
●	○	3min
○	○	10min

**Daylight Sensor – 4 & 5**

Adjusts the minimum light (lux) levels required before the LED light changes to Sensing Mode. The light level threshold must be reached



4	5	
●	●	2000Lux
○	●	50Lux
●	○	15Lux
○	○	5Lux

**Stand-by Period – 6 & 7**

Adjusts the period of time the LED light stays dimmed in Sensing Mode after On-Time Delay has elapsed. When dimmed, the light is at 10%/20% brightness. Light can be switched off without dimming (0s), dimmed for a period of time (30s, 10min) or remain dimmed indefinitely (+∞).



6	7	
●	●	0S
○	●	30S
●	○	10min
○	○	+∞

**Stand-by Dimming level - 8**

Adjusts dimmed low light output level during Stand-by Period.



8	
●	10%
○	20%

**WIRING:**

- Connect the two sensor wires together.
- Connect the AC power supply into the “L N” port.

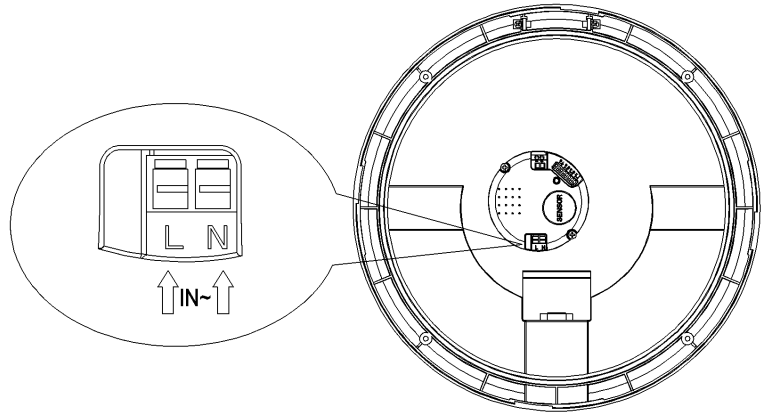

**TEST:**

- Turn every DIP switch to the “On” position (as pictured right).
- While powered on, the light should turn on to 100% brightness. After 10 seconds of no motion, the light should fully turn off without dimming. When movement is detected, it should turn back on to 100% brightness.
- Adjust the Stand-by Period to 30s. After 10 seconds of no motion, the light should now dim to 10% for 30 seconds before fully turning off. When movement is detected, it should turn back on to 100% brightness.

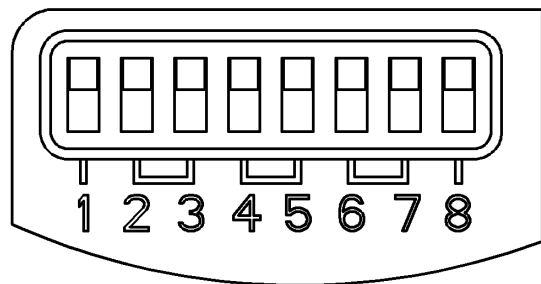

	Detection Range	Hold Time	Daylight Sensor	STBY	STBY%
	1	2 3	4 5	6 7	8
	● 100% ○ 50%	●● 10S ○● 90S ●○ 3min ○○ 10min	●● 2000Lux ○● 50Lux ●○ 15Lux ○○ 5Lux	●● 0S ○● 30S ●○ 10min ○○ +∞	● 10% ○ 20%

**Note: when testing in daylight, please set Daylight Sensor to 2000lx, otherwise the sensor light will not work properly.**

**TROUBLESHOOTING:**

- **The light isn't turning on.**
    - Check the power supply is properly connected.
    - Check to see whether the motion detector is working by the indicator light.
    - If the indicator light does not activate, check the Daylight Sensor DIP switch settings. The ambient lux may be too high for the light to turn on.
  - **Motion detection is weak.**
    - Check the front of the sensor to ensure it isn't obstructed.
    - Change the Detection Range DIP switches to 100% to ensure highest sensitivity.
    - Check the installation height. The light should not be installed more than 8m from the ground.
  - **On-Time Delay won't activate.**
    - Check the On-Time Delay DIP switch settings to see the required delay time.
    - Test by ensuring no movement is in front of the motion sensor for that delay time.
- c. If the power corresponds to the instruction.