

# Ultimate Series 1080p 20x Zoom HDCVI PTZ

Model: VSCVI2MPPTZIR



Every moment captured with the Securview HDCVI PTZ series. Enjoy Full HD 1080p streaming, convenient endless 360° panning at 240°/s preset speed, and high-power infrared up to 100m.

## Camera Features

- Streams Full HD 1080p/2.0MP (1920 x 1080)
- Motorised 4.7 ~ 94mm lens, auto iris
- 54.1 ~ 3.2° horizontal viewing angles
- Up to 300m HD video transmission over coax
- Infrared illumination up to 100m
- IP66 for weather resistant housing
- HD/SD switchable output for analogue DVRs
- Endless 360° panning, 105° tilt-range & auto-flip 180°
- Alarm and audio I/O interface
- Digital WDR & 3D noise reduction

## Compatible Accessories

Accessories sold separately, additional adapters may be required.



VSBKTA114



VSBKTA120



VSBKTA140



VSBKTB300C



VSBKTA150

Model	VSCVI2MPPTZIR
<b>General</b>	
Camera Style	Weather Resistant PTZ Dome
Image Sensor	1/2.8" 2.0 Megapixel Exmor CMOS
Effective Pixels	1920 (H) x 1080 (V)
Signal Noise Ratio	> 50dB
<b>Camera</b>	
Lens	4.7 ~ 94mm Motorised Lens; Auto Iris
Angle of View	54.1° (wide) ~ 3.2° (tele)
Electronic Shutter	1/1 ~ 1/30,000s
Minimum Illumination	0.05 Lux at F1.4 (Colour) / 0 Lux IR Active
Day/Night	Auto (ICR) / Colour / B&W
White Balance	Auto, ATW, Indoor, Outdoor, Manual
Noise Reduction	2D / 3D
Gain Control	Auto/Manual
Backlight Compensation	BLC / HLC / DWDR
Audio Input	1 channel in
Transmission Distance	Up to 300m via 75-3 coaxial cable
Synchronisation	Internal
OSD Menu	Support
Alarm Interface	2 channel in / 1 channel out
<b>Video</b>	
Video Compression	H.264 / MJPEG
Resolution	1080p (1920 x 1080) to CIF (352 x 288)
Frame Rate	25fps (1080p and lower)
Video Output	BNC CVI HD output / CVBS SD output (switchable)
<b>PTZ</b>	
RS485	1 input
Pan/Tilt Range	Pan: 0° ~ 360° endless / Tilt: -15° ~ 90° / Auto-flip 180°
Manual PTZ Speed	Pan: 0.1° ~ 160°/s; Tilt: 0.1° ~ 120°/s
Preset PTZ Speed	Pan: 240°/s; Tilt: 200°/s
Presets	300(DH-SD) / 255(Pelco-P/D)
PTZ Modes	5 Pattern / 8 Tour / Auto Pan / Auto Scan
Protocols	DH-SD / Pelco-P/D (Auto Recognition)
<b>Environment</b>	
Ingress Protection	IP66
Vandal Resistant	No
Maximum Infrared Range	100m
Power Input	24VAC 3A ±10%
Power Consumption	10.5W / 26W (IR active)
Dimensions	Ø205 x 360mm
Weight	7.5kg
Operating Environment	-40° to 60°C / RH90% (max)
<b>Product Diagram</b>	

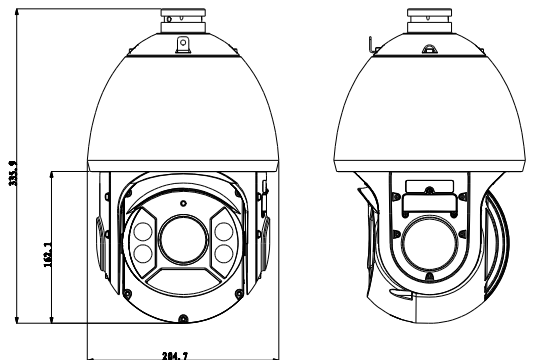

Your local Securview™ professional: