

# ACLOC102 Monitored Mortise Electric Door Strike

1. Prepare door jamb per drawing.
2. Install mounting brackets to jamb using M4×11 screws & pressed metal nuts. Do not tighten.
3. Spacers are provided to assure flush final assembly of faceplate into jamb. Add one or more spacers between jamb & mounting bracket when face plate extends beyond the jamb. When the faceplate sets inside the jamb, spacers must be added between the mounting bracket & the tip bracket. Make sure clearance

4. Connect wires coming from the low voltage side of the transformer to wires (black) from strike.
5. Install electric strike jamb by attaching with #10-32 screws and lockwashers.
6. Secure M4x11 screws holding mounting brackets to jamb.
7. Door Status Sensor(Closed position)
  - Blue = NO    White = COM
  - Yellow = NC

- Lock Status Sensor(Lock position)
- Green = NO
  - Grey = COM
  - Orange = NC
- POWER    Black,Black(12VDC,24VAC)  
              White,White(24VDC)
8. A varistor is provided to prevent strike from spike. Connect varistor to between input wires.
  9. How to modify fail-safe to non fail-safe or vice versa.

- (1). Unscrew the electric strike as per the product diagram below.
- (2). Reverse solenoid to the opposite side then close.

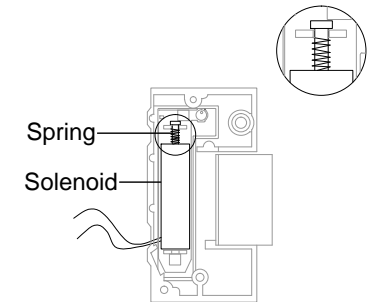
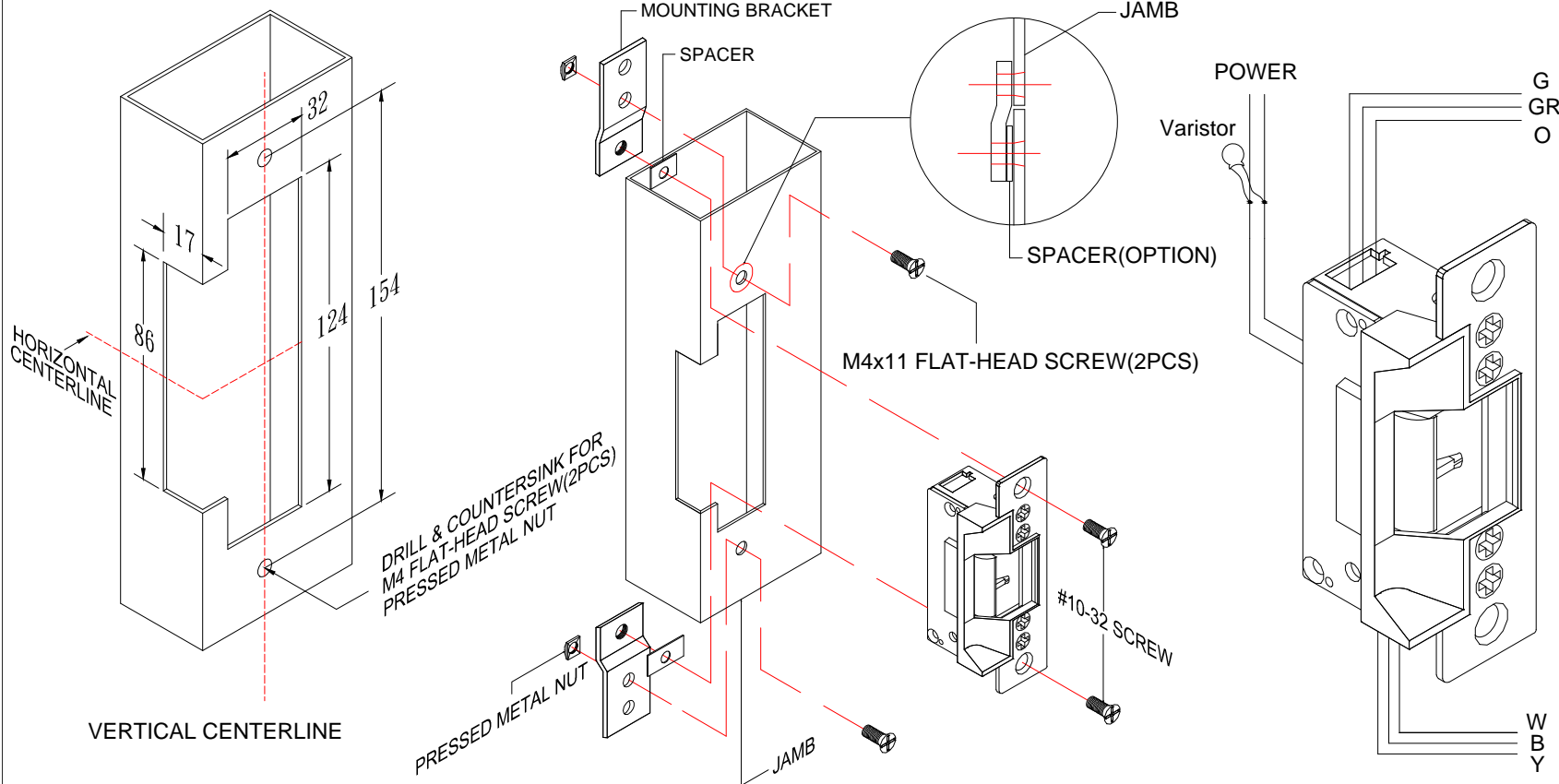

Fail-safe type

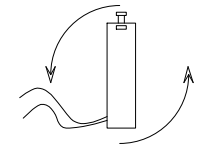

Reverse solenoid

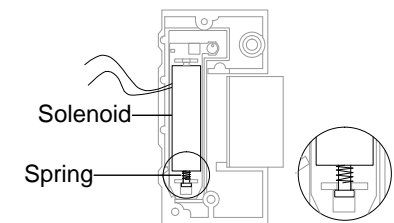

Non Fail-safe type