

Solar-Powered Dual-Tech Motion Detector

PIR-926

User Manual

Introduction

PIR-926 is a solar-powered motion detector utilizing a single passive infrared element and microwave technology. It consists of digital dual-core fuzzy logic infrared control chip and intelligent analysis which effectively identify interference signal from body movement signal and reduce false alarm. The detector is battery powered and kept re-charging by the solar panel to save energy. Unique housing material and structure improves waterproof level for outdoor use. Only after being connected successfully with alarm system, the detector can work normally.

Features

- Accurate detection**
 - It has microwave and infrared dual detections to prevent false alarm.
 - It consists of digital dual-core fuzzy logic infrared control chip and intelligent analysis which effectively identify interference signal from body movement signal.
 - With automatic temperature compensation and anti-air turbulence technology, it easily adapts to environmental changes.
- Outdoor use**
 - It adopts ABS and anti-UV material for outdoor use with IP65 rating.

3. Energy saving

- Rechargeable by solar power.
- Energy saving mode to reduce battery charging times, extending battery life.

Product Overview

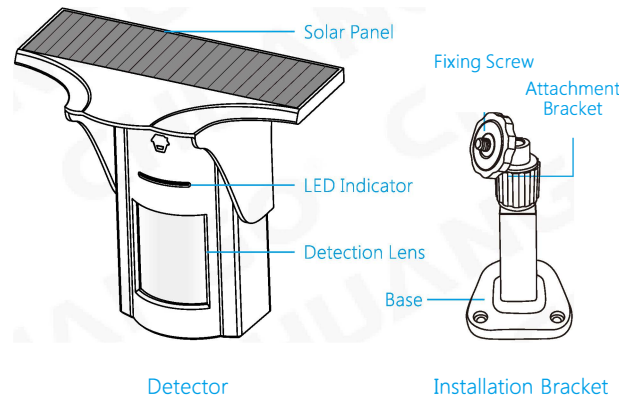

LED Indication

LED Status	Meaning
Red and orange LED flash continuously for 1min	Self-testing
Red LED flashes once	Infrared is triggered
Orange LED flashes once	Microwave is triggered
Red and orange LED flash once at the same time	Both infrared and microwave are triggered, the detector sends alarm signal.
Red LED flash 3 times every 12 seconds	Low battery, please install on place with sufficient sunlight

PCB Layout

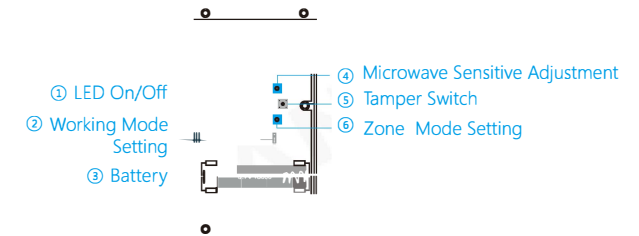

- LED options: ON/OFF (default setting is ON).
- Working mode options: 10S=Test mode, 5MIN=Power saving mode (default setting is test mode).
- Battery: One piece of 18650 rechargeable lithium battery.
- Microwave sensitivity adjustment options: HIGH, MEDIUM, LOW. (default setting is medium).
- Tamper switch: In working state, if the housing is opened, detector will send alarm signal.
- Zone mode options: Normal zone, home zone, 24-H zone (default setting is normal zone).

Normal zone: In arm or home arm state, the detector set at normal zone will trigger an alarm once intrusion is detected.

Home zone: In home arm state, the detector set at home zone is disarmed.

24-H zone: The detector set at 24-H zone will trigger an alarm once intrusion is detected, no matter the system is armed or disarmed.

Detection Scope

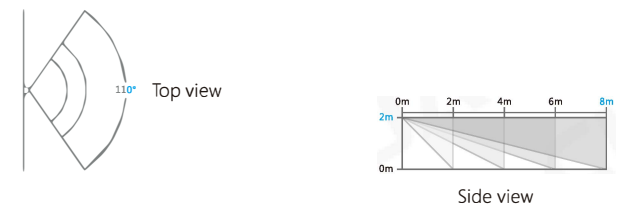

Working Mode Selection

After the battery is loaded, the detector enters 1min self-testing with the red and orange LED flashing continuously, and then it starts to work according to the pre-set working mode.

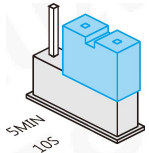

Testing Mode

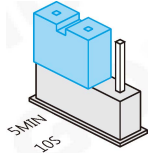

Power Saving Mode

Testing mode (default setting): The detector detects once every 10 seconds.

Power saving mode: The detector enters a 5-minute testing mode firstly, and then switches to power saving mode.

If the detector detects movements twice in 5 minutes, it automatically goes into asleep state. If there is no movement detected in next 5 minutes, it will switch from asleep state to arm. As long as there is a movement detected within 5 minutes, the duration of power saving mode will be extended.

Note: It is suggested to set the detector in power saving mode for daily use to save power.

Test

Remove the battery activation strip. After red and orange LED flash continuously for 1min, it enters working state. By then, put the detector on a shelf, walks from the left to right(or right to left) within the detection scope to trigger it, red and orange LED will flash once. This indicates the detector is working properly.

Installation & Notices

Installation steps:

1. Make the attachment bracket and base apart.
2. Fix the base on the right place (see notices).
3. Tighten the attachment bracket with the detector.
4. Tighten the attachment bracket with the base and adjust to proper detecting angle.

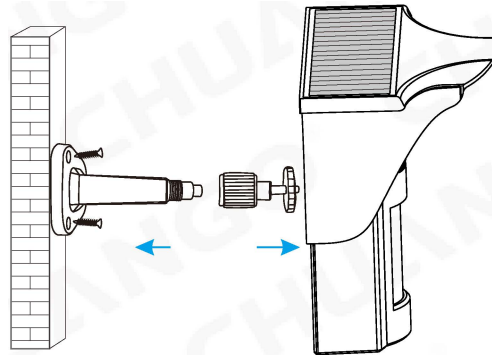

Notices:

1. It is recommended to mount the detector at height of 2m from the ground.
2. The detector is more sensitive to cross movement than vertical movement, so it is suggested to mount it facing vertical to the walking direction of people.
3. Please avoid big objects in front of the detector which will influence the detection.
4. Please avoid any cases that pets can climb over to avoid false alarm.
5. As it is a solar-powered detector, please install it where adequate sunlight is ensured.

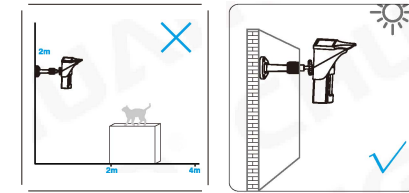
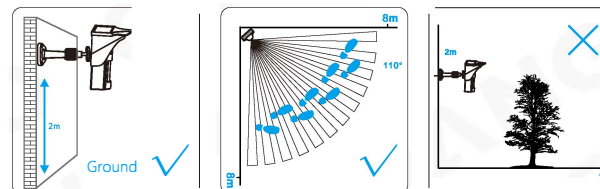

Connect to Control Panel

Make sure the control panel is in pairing state, trigger the detector to alarm until the panel gives out a beep, which indicates the connection succeeded. Arm the system, trigger the detector again, the siren of control panel will hoot which confirms the connection is successful.

Specifications

Power supply:

18650 3.7V 1800mAh rechargeable lithium battery

Standby current: <0.16mA

Solar panel output current: 2000LX illumination \geq 4mA

Battery standby time: <180 days

Detection scope: 8m/110°

Wireless transmitting distance: <80m (in open area)

Radio frequency: 315MHz or 433.92MHz (\pm 75KHz)

Operating condition:

Temperature -10 °C ~ +55 °C

Relative humidity <80% (non-condensing)

Housing material: PC+ABS+ANTI-UV

Detector dimensions (L x W x H): 186 x 200 x 125mm

Bracket dimensions (L x W x H): 75 x 72 x 155mm