

Self-Contained Access Control Reader

CE

RFID



AR-2808
User Manual

TABLE OF CONTENTS

INTRODUCTION	3
SPECIFICATIONS	3
Package Contents	3
THE FRONT PANEL	4
Status Indicator (Blue)	4
Operation Indicators	4
Card Reader Window	4
Door Bell Button (Function Selector)	4
INSTALLATION	5
Precautions for Installation Location	5
Precautions for Accidental Short Circuit	5
Precautions for Electric Spikes & Back EMF	5
THE CONNECTION TERMINALS	6
1 - 2 : 12VDC (Power Input Terminal)	6
3 : (+) 12V Power Supply for The Lock	6
4 : (-) Power Supply for The Lock (Output Contact for Door Lock Strike)	6
5 : EG IN (Egress Input for N.O. Button)	7
6 : Data I/O Port	7
7 - 8 : Door Bell (Relay Contact for Optional Door Chime)	7
9 - 10 : Tamper Switch (Tamper Switch with N.C. Contact)	7
CREATE A MASTER CARD (CMC)	8
The First Step before Programming - Make A Madter Card	8
Procedures of Creating A New Master Card with CMC Jumper	8
PROGRAMMING	9
1) Criteria for Setting System to Programming Mode	9
2) Use The Master Card to Set System into Programming Mode for The 5 Feature Groups ..	9
3) The Reading Manner for Master Card	9
4) Audible Indications in Programming & Operation	9
I) RECORD USER CARD(S) – Feature Group 1	10
II) DELETE USER CARD(S) – Feature Group 2	11-12
III) SET OUTPUT MODE FOR DOOR LOCK -- Feature Group 3	13
IV) SET SYSTEM SAFETY LOCK-UP -- Feature Group 4	14
V) CREATE / DELETE SUPER USER CARD(S) -- Feature Group 5	15-16
OPERATION	17
FEATURE SETTING PROCEDURES SUMMARY CHART	18-19
APPLICATION EXAMPLES	20
1) Stand Alone Access Control Electric Lock	20
2) Application Hints for The Auxiliary Terminals	20
APPLICATION EXPANSION – The Optional Auxiliary Reader AR-2802	21
Multi- Station Access Control Electric Lock	22

INTRODUCTION

AR-2808 is a self-contained access control reader designed to drive electric door lock directly. It accommodates up to 500 proximity EM cards and its output is compatible with the Fail-safe and Fail-secure electric locks. The door lock striking time is programmable. A built-in door chime relay contact is also available to operate an external low power door chime. It is a full feature compact reader ideally for the access control system in small office and home applications. The system employs solid state switch instead of relay contact for door lock strike. It gives longer service life and prevents the sabotage of opening the door with strong magnet.

AR-2808 is built-in with Data I/O bus for system expansion. Maximum three optional card readers (AR-2802) can be connected with it to make a multi-station access control system.

SPECIFICATIONS

- Operation Voltage: 12VDC Nominal, 11-16VDC
- Operating Current: 60mA (quiescent), 80mA Maximum
- Storage & Operation Temperature: -20°C to +70°C
- Storage & Operation Humidity: 5-95% Relative Humidity, Non-condensing
- Working Environment & Ingress Protection: Indoor or Outdoor, IP-55 Weatherproof
- Number of User Cards: 500, Standard 125Khz Proximity EM Cards or Keyfobs
- Number of Super User Cards: 5, Standard 125Khz Proximity EM Cards or Keyfobs
- Safety Lock-ups: a) No Lock-up, b) Auto Lock-up after Invalid Trials, & c) Manual Lock-up with Super User Card
- Door Lock Operating Timer: 1-60 Seconds Programmable
- Egress Button: Normally Open (N.O.) Button(s) for Request to Exit from Inside
- Data I/O Bus for Optional Card Readers (AR-2802). Accommodates 3 Optional Readers Max.
- Bell Button: Output Relay Contact for Actuating An Optional Door Chime
- Output Contact Ratings:
 - a) Solid State Output for Lock Strike – Fail-safe or Fail-secure Selectable, 3A/16VDC Max.
 - b) Door Chime Relay – N.O. Dry Contact, 1A/24VDC Maximum
 - c) Tamper Switch – N.C. Dry Contact, 50mA/16VDC Maximum
- Dimensions: 60(W) X 119(H) X 23(D) mm
- Weight: 160g Net
- Housing: ABS Plastic

Specifications are subject to change for modification without notice

PACKAGE CONTENTS

- One AR-2808 Reader
- Two EM Cards
- One Pack of Mounting Screws
- One Hex Socket Screw Wrench
- One User Manual

THE FRONT PANEL

AR2808 FRONT PANEL

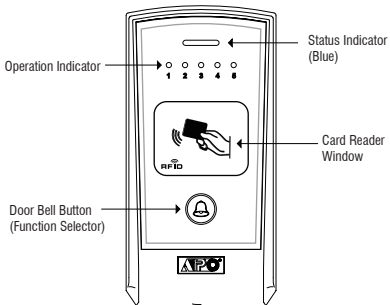

- **Status Indicator (Blue)**

It is ON in normal operation. It flashes during programming mode or lock-up mode.

- **Operation Indicators**

The 5 LED indicators with number 1, 2, 4 and 5 in green and number 3 in amber color show the status of the system in Operation Mode or in Programming Mode.

- 1) They indicate the Storage Group of an EM card when it is read in Operation Mode.
- 2) They show the status of feature settings in Programming Mode. See “**Programming**” & “**Operation**” sections for the details.

- **Card Reader Window**

It is a place for reading EM cards.

- **Door Bell Button (Function Selector)**

This button has two functions. It is a door bell button in normally operation and is a function selector in programming mode. See the details in “**Programming**” & “**Operation**” sections.

INSTALLATION

AR-2808 ASSEMBLY

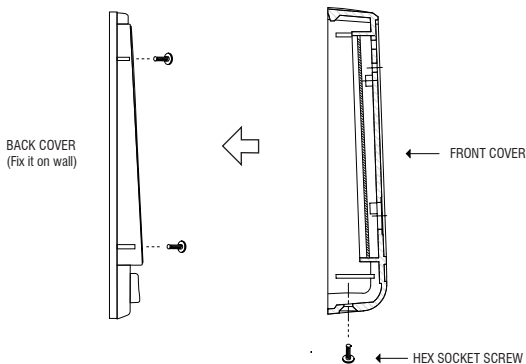

Precautions for Installation Location

The EM Card works at the frequency of 125Khz. Installation precautions are necessary:

- Make sure the location has no strong low frequency electro-magnetic wave signals near it. Especially in the range of 100-200Khz.
- If more than one keypads / readers operating in the same frequency, make sure that they are at least 60cm (2ft) apart from each other. Otherwise, the reading range may be reduced due to interference.

Precautions for Accidental Short Circuit











In the previous experience, most of the damages caused during installation are accidental touch of the components on the circuit board with the wire(s) carrying power. The following precautions are necessary:

- Study the manual thoroughly to become familiar with the system before installation.
- Do Not apply power to any connection terminal of the reader during installation.
- Check all the wirings carefully and confirm that they are correct before applying power to the reader for testing.

Precautions for Electric Spikes & Back EMF

Make sure to connect the diode (supplied) or a varistor (MOV) across the electric lock's power input terminals to absorb the back EMF and the electric spikes. Fail to do so may cause damage to the electronic components; in worst case, even burn out the reader.

THE CONNECTION TERMINALS

1	2	3	4	5	6	7	8	9	10
									
(+) (-) 12VDC		(+) (-) DOOR LOCK		EG IN	DATA I/O	DOOR BELL N.O.		TAMPER N.C.	

1 - 2 : 12VDC (Power Input Terminal)

Connect (+), terminal 1 to a 12V DC power supply. The (-), terminal 2 is the common grounding point of the system. Make sure the power supply can provide enough power for the electric lock and the reader.

3 : (+) 12V Power Supply for The Lock

A (+) supply point for the electric lock, which is common to terminal 1.

4 : (-) Power Supply for The Lock (Output Contact for Door Lock Strike)

A 3 Amp rating solid state switch output contact for electric door lock strike, it switches to (-) in operation. It is selectable for operating Fail-safe or Fail-secure electric lock via jumper setting. Connect the negative side (-) of the electric lock to this terminal and the positive side (+) to terminal 3. The operating time of the contact is programmable. Please see “**Set Output Mode for Door Lock**” for the details.

Important

Two types of electric locks are available on the market. It is necessary to confirm that the lock is Fail-safe or Fail-secure in order to make the correct jumper selection. **Wrong selection may cause damage to the lock or the reader.**

- **Fail-safe Electric Lock** – Normally energized; power ON to lock, power OFF to unlock
- **Fail-secure Electric Lock** – Normally de-energized; power ON to unlock, power OFF to lock

Door Lock Selection Jumper

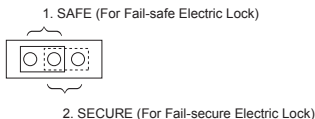

DOOR LOCK

5 : EG IN (Egress Input for N.O. Button)

A Normally Open (N.O.) input terminal referring to (-) ground for connecting N.O. button to activate the output contact for door lock strike. Egress button is usually put inside the house near the door for "request to exit". More than one egress buttons can be connected in parallel to this terminal for user convenience at other location(s), such as near the reception desk. Leave this terminal open if not used.

6 : Data I/O Port

A data communication port prepared for the optional reader AR-2802 connection to expand the access control system with two or more readers. The enrolled EM cards in the AR-2808 are also accepted by the optional readers.

7 - 8 : Door Bell (Relay Contact for Optional Door Chime)

A Normally Open (N.O.) relay dry contact with maximum rating of 1Amp/24VDC controlled by the BELL button, it is prepared to trigger an optional low voltage door chime. The contact point keeps close as long as the bell button is pressed.

9 - 10 : Tamper Switch (Tamper Switch with N.C. Contact)

A Normally Closed (N.C.) dry contact while the reader is fixed on its back cover. The contact is open while the reader is separated from its back cover. Connect this N.C. terminal to the 24 hour protection zone of an alarm system if necessary in order to get alert from sabotage.

CREATE A MASTER CARD (CMC)

The First Step before Programming- Make A Master Card

- The system needs a Master Card to set it into programming mode. **Before programming, it is necessary to make a Master Card by the owner.**
- In case the Master Card is lost, it is necessary to make a new Master Card to replace it. Once a new Master Card is made, the old one is invalid.

Procedures of Creating A New Master Card with CMC Jumper:

1) Switch OFF power to the reader completely

2) Put the CMC Jumper from OFF to ON position (The jumper is on the circuit board)

3) Switch ON power again.

Response : The reader gives continuous beeps. The Status LED (blue) starts to flash for one minute. This is the allowed time for making a Master Card.

4) Put the jumper back to OFF position.

Response : The beep stops.

5) Read an EM card (a new EM card or keyfob).

Response : Two beeps confirm reading successful.

6) Press the Bell button 1 Time to save the Master card and exit CMC mode.

Response : Two beeps confirm reader back to normal operation. The Status LED is ON.

7) Label the card as MASTER.

It is a card for programming authorization purpose. Do not mix it with other User Cards and keep it in a safe place.

CMC JUMPER

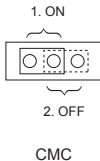

NOTE:

The system will **get stuck and the status LED will turn OFF** if the Master Card can not be made within the allowed time of one minute. It is necessary to repeat procedures 1-6 and try again.

1) Criteria for Setting System to Programming Mode

- The system is in standby under Normally Operation
- A Master card is already in possession

2) Use The Master Card to Set System into Programming Mode for The 5 Feature Groups.

- **Feature Group 1** -- Record User Cards (Read Master Card 1 Time)
- **Feature Group 2** -- Delete User Cards (Read Master Card 2 Times)
- **Feature Group 3** -- Set Output Mode for Door Lock (Read Master Card 3 Times)
- **Feature Group 4** -- Set System Safety Lock-up (Read Master Card 4 Times)
- **Feature Group 5** -- Create / Delete Super User Cards (Read Master Card 5Times)

3) The Reading Manner for Master Card.

- Set system to Programming Mode with reading of Master Card 1 to 5 times for the 5 feature groups. Each reading must be within 2 seconds.
- Read Master Card 1 time to close Programming Mode.

Note:

The reader will stay in Programming Mode until it is closed with Master Card.

4) Audible Indications in Programming & Operation

- 1 Beep – Step jumping in feature selection
- 2 Beeps – Execution successful
- 5 Beeps – Execution failed
- 1 Long Beeps – Rejection to a repeated card in programming mode

I) RECORD USER CARDS – Feature Group 1

There are 5 Storage Groups available for storing total 500 User Cards. For easy management, each group accommodates 100 user cards maximum. The indicator LED of the storage group is ON for vacancy available and flashing for vacancy full.

This system is designed for small office or home that does not have large number of users. It is suggested to put user cards evenly into the 5 Storage Groups. For example, evenly put 5 User Cards each into the 5 groups for an office of 25 staff. In case group clearing is required, only to clear the group that holds the lost card.

It is suggested to make a list recording the User Number and the Name of the card holders for each of the Storage Groups before programming. It will be helpful to record the cards smoothly and also to trace them from the system afterward in case a card is lost.

Storage Group 3....5		
Storage Group 2		
Storage Group 1		
User Number	Name of Holder	Remark
1	John	Sales Dept
2	Tracy	Sales Dept
3	Nancy	Admin Dept
4	Alan	Eng Dept
5	Paul	Eng Dept
6	Mary	Accounts Dept
-	-	-
-	-	-
-	-	-
100		

Procedures

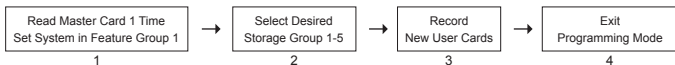

1) Read Master Card 1 Time to set system to Feature Group 1 – Record User Cards.

Response : Status LED (blue) starts to flash during programming mode and group LED 1 is ON. After 2 seconds, the system confirms the selection with 2 beeps and the 5 group LEDs flashing for five storage groups available.

2) Press BELL button to select one of the 5 Storage Groups for storing the User Cards.

Response : The selected group LED is ON for vacancy available. After 2 seconds the system confirms the selection with 2 beeps. The selected group LED stays flashing for vacancy full without confirmation.

3) Record the User Cards

They can be read and appended one by one into the desired Storage Group.
Response : 2 Beeps confirm successful for each card recording.

4) Read Master Card 1 Time to exit Programming Mode.

Response : 2 Beeps confirm reader back to normal operation.

NOTE:

- Press BELL button to select other Storage Groups with the above procedures 2 & 3 before close of programming mode.
- All the User Cards must be unique in the system. Repeat recording of same card into other groups will be rejected. One long beep indicates rejection of a repeated card.

II) DELETE USER CARD(S) – Feature Group 2

The User Card(s) can be removed from the system if it is not used or lost. Three deletion modes are available.

Deletion Mode 1 – Delete un-used card

Deletion Mode 2 – Delete lost card

Deletion Mode 3 – Delete a group of cards (Group clearing)

Procedures

1) Read Master Card 2 Times to set system to Feature Group 2 – Delete User Card(s).

Response : Status LED (blue) starts to flash during programming mode and group LED 2 is ON.
After 2 seconds, the system confirms the selection with 2 beeps and the group LED 1, 2 & 3 flashing for the three deletion modes available.

A) Deletion Mode 1 – Delete un-used card:

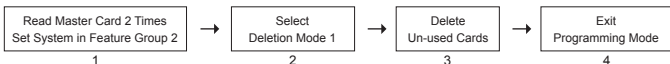

2) Press BELL button to select deletion mode 1.

Response : LED 1 is ON. After 2 seconds, the system confirms the selection with 2 beeps.

3) Read the un-used card(s).

They can be read and appended one by one to delete from the system.

Response : The card's Storage Group LED lights up for 1 second and 2 Beeps are generated for each card deletion.

4) Read Master Card 1 Time to exit Programming Mode.

Response : 2 Beeps confirm reader back to normal operation.

B) Deletion Mode 2 – Delete lost user card:

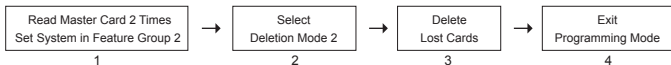

2) Press BELL button to select deletion mode 2.

Response : LED 2 is ON. After 2 seconds, the system confirms the selection with 2 beeps.

3) Read the user card that the lost card followed.

Example, the lost user card is #4, then, read the user card of #3 to delete it. Delete other lost cards one by one in the same manner.

Continuous reading of user card #3 will also delete the succeeding user cards # 5, 6, 7 -- etc. As card #5 becomes the succeeding card of #3 after deleting #4, and so on.

Response : The LED of the lost card's storage group lights up for 1 second and 2 Beeps are generated for each card deletion.

Remark:

For the lost user card of number 1 in its group and has no user card in front of it, then read the **Super User** card of its group to delete it. The 5 user groups each one has its Super User card. See Create Super Cards in page 15 for the details.

4) Read Master Card 1 Time to close Programming Mode.

Response : 2 Beeps confirm reader back to normal operation.

Note:

There is a slot left at the memory stack after a card is deleted. In programming, the new cards will fill in the slots first according to their position in the queue of the memory stack. After all the slots are filled, then the cards will go to the vacancies available at the end of the list.

Example: An User list before and after deleting Nancy and Alan's user cards, there are 2 slots (3 & 4) left.

Before	After
1. John	1. John
2. Tracy	2. Tracy
3. Nancy	3. -- (Slot)
4. Alan	4. -- (Slot)
5. Paul	5. Paul
6. -- (Vacancy)	6. -- (Vacancy)

This is the programming manner of putting three new user cards into the system with slots, the 1st one goes to the 1st slot (#3), the 2nd one goes to the 2nd slot (#4) and the 3rd one goes to the vacancy (#6) available at the end of the list.

C) Deletion Mode 3 – Delete one group of user cards (Group clearing):

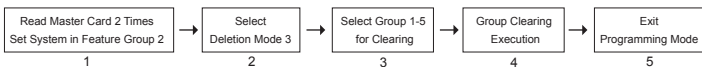

2) Press BELL button to select deletion mode 3.

Response : LED 3 is ON. After 2 seconds, the system confirms the selection with 2 beeps and then the 5 LEDs flashing for five storage groups available.

3) Press BELL button to select the storage group 1-5 for group clearing.

Response : The selected LED is ON. After 2 seconds, the system confirms the selection with 2 beeps.

4) Press BELL button again to execute group clearing.

Response : The group LED flashes during clearing and 2 Beeps confirm clearing done.

Note: Repeat procedure (3) & (4) for clearing of other storage groups if required.

5) Read Master Card 1 Time to exit Programming Mode.

Response : 2 Beeps confirm reader back to normal operation.

Remark:

After Group Clearing, it is necessary to re-store all the existing (not lost) User Cards back to the Storage Group one by one with the procedures stated in the "Record User Cards – The Feature Group 1" section.

IV) SET SYSTEM SAFETY LOCK-UP -- Feature Group 4

The reader can be protected with safety lock-up to prevent trials with un-recorded cards. There are three options for owner's selection. Only one option can be selected in programming.

Option 1 -- No lock-up function at all (ex-factory setting)

Option 2 -- Lock-up during 60 seconds after 10 false trials

Option 3 -- Lock-up during 15 minutes after 10 false trials

Procedures -- Options 1, 2 or 3

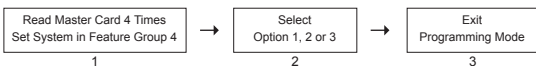

1) Read Master Card 4 Times to set system to Feature Group 4 – Set System Safety Lock-up.

Response : *Status LED (blue) starts to flash during programming mode and group LED 4 is ON. After 2 seconds, the system confirms the selection with 2 beeps and the group LED 1, 2 & 3 flashing for the three options available.*

2) Press BELL button to select the desired option 1, 2 or 3.

Response : *The LED of the desired option is ON. After 2 seconds, the system confirms the selection with 2 beeps.*

3) Read Master Card 1 Time to exit Programming Mode.

Response : *2 Beeps confirm reader back to normal operation.*

Note: The system counts each successive trial within 30 seconds and it resets if no reading of card.

V) CREATE / DELETE SUPER USER CARDS -- Feature Group 5

The Super User cards are prepared for the owner or the trustworthy executives, which have **TWO functions** that are **system lock-up** and **door open**. Total five Super User Cards can be created with one for each user group.

- Lock-up the system during the time of “after-office-hours” or the house of nobody inside. Lock-up Release is in toggle manner.
- Release the system from Lock-up instantly at anytime.
- Act as Owner’s private user card for door open at any condition including in the system lock-up period.

Procedures

1) Read Master Card 5 Times to set system to Feature Group 5 – Create / Delete Super User Cards.

Response : Status LED (blue) starts to flash during programming mode and group LED 5 is ON. After 2 seconds, the system confirms the selection with 2 beeps and the group LED 1 & 2 flashing for the two options available.

A) Create Super User Card(s) – Option 1



2) Press BELL button to select Option 1 -- Create

Response : LED 1 is ON. After 2 seconds, the system confirms the selection with 2 beeps and then the 5 LEDs flashing.

3) Press BELL button to select a location 1-5 for one of the Super User Cards.

Response : The selected LED stays ON. After 2 seconds, the system confirms the selection with 2 beeps.

4) Read a new User Card once to make it Super User Card

Please marked it Super User with location number; location 1 belongs to Storage Group1.

Response : 2 Beeps confirms successful.

Note: a) Repeat procedures (3) & (4) to record Super User Cards at other locations if required. Total 5 Super Cards can be made.

b) The new card replaces the old card if there was an old card in the location.

5) Read Master Card 1 Time to exit Programming Mode.

Response : 2 Beeps confirm reader back to normal operation.

B) Delete Super User Card(s) – Option 2

In case a Super Card is lost, it can be deleted from the system.



2) Press BELL button to select Option 2 -- Delete

Response : LED 2 is ON. After 2 seconds, the system confirms the selection with 2 beeps and then the 5 LEDs flashing.

3) Press BELL button to select the storage location 1-5 for card deletion.

Response : The selected LED is ON. After 2 seconds, the system confirms the selection with 2 beeps.

4) Press BELL button again to execute card deletion.

Response : 2 Beeps confirm clearing done.

Note: Repeat procedure (3) & (4) for other Super User Card(s) deletion if required.

5) Read Master Card 1 Time to exit Programming Mode.

Response : 2 Beeps confirm reader back to normal operation.

1) Read User Card to Open Door

- Read User Card **once**.
- Two beeps confirm success of reading a valid user card and its group LED turns ON during the door lock strike.
- Five beeps are generated for invalid card.

2) Read Super User Card to Open Door

- Read Super User Card **twice within 3 seconds**.
- Two beeps confirm success of reading a valid super user card and its group LED turns ON during the door lock strike.
- Five beeps are generated for invalid card.

Note:

Super User Card is valid all the time in both Normal & System Lock-up conditions.

3) Read Super User Card to Make System Lock-up

- Read Super User Card **once**, and then, press **BELL button once within 3 seconds**.
- Two beeps confirm success. The Status LED (blue) flashes slowly (0.5sec ON, 1sec Off) during the system lock-up in effect.
- Five beeps are generated for invalid card.

Note:

- During the lock-up time, the Status LED (blue) flashes slowly and the reader refuses all the general user cards except the Super User cards.
- The Egress Button works normally all the time and is not affected by the lock-up function.
- The Door Bell button works normally all the time and is not affected by the lock-up function.

4) Read Super User Card to Release System Lock-up

- Read Super User Card **once**, and then, press the **BELL button once within 3 seconds**.
- Two beeps confirm success. System goes back to normal operation and the Status LED (blue) turns ON from flashing.
- Five beeps are generated for invalid card.

FEATURE SETTING PROCEDURES SUMMARY CHART

ENTER PROGRAMMING MODE & FEATURE GROUP SELECTION WITH MASTER CARD	FUNCTION SELECTION WITH BELL BUTTON	SELECTION & EXECUTION	EXIT PROGRAMMING MODE
I) RECORD USER CARDS Read Master Card ON for 1 TIME Status LED ON ► Flashing Feature Group 1 Selected Auto-Confirm LED 1 - ON ► All 5 LEDs Flashing	Storage Group 1-5 ► Auto - Confirm Group LED ON - Vacancy Available Flashing -- Full	Read New User Cards Group LED ON for 1 Second / Card	Read Master Card ON for 1 TIME Status LED ON System Back to Normal operation
II) DELETE USER CARDS Read Master Card ON for 2 TIMES Status LED ON ► Flashing Feature Group 2 Selected Auto-Confirm LED 2 - ON ► LED 1, 2 & 3 Flashing	Deletion Mode 1 ► Auto - Confirm LED 1 -- ON ► 2 Beeps Deletion Mode 2 ► Auto - Confirm LED 2 -- ON ► 2 Beeps	Read Un-used Cards The Group LED of the Deleted Card ON for 1 Second / card Read The Card of The Lost Card Follows	
III) SET OUTPUT MODE FOR DOOR LOCK Read Master Card ON for 3 TIMES Status LED ON ► Flashing Feature Group 3 Selected Auto-Confirm LED 3 - ON ► LED 1 & 2 Flashing	Deletion Mode 3 ► Auto - Confirm LED 3 -- ON ► 5 LEDs Flashing Mode 1 - Start / Stop ► Auto - Confirm LED 1 -- ON Flashing Mode 2 - Timing ► Auto - Confirm LED 2 -- ON Flashing	Select The Group 1-5 For Cleaning ► Auto - Confirm Execution with Bell Button. The Selected Group LED - ON Flashing During Cleaning To " Ext Programming Mode " Directly ►	
IV) SET SYSTEM SAFETY LOCK-UP Read Master Card ON for 4 TIMES Status LED ON ► Flashing Feature Group 4 Selected Auto-Confirm LED 4 - ON ► LED 1, 2 & 3 Flashing	Option 1 - 3 ► Auto - Confirm The Selected LED - ON ► Flashing To " Ext Programming Mode " Directly ►	LED Jumper ► ON & Stop at Desired Time	

FEATURE SETTING PROCEDURES SUMMARY CHART -- CONTINUE

V) CREATE / DELETE SUPER USER CARDS																			
<div style="border: 1px solid black; padding: 5px; margin-bottom: 5px;"> Read Master Card 5 TIMES Status LED ON ► Flashing </div>	<table border="1" style="width: 100%; border-collapse: collapse;"> <tr> <td style="width: 25%; padding: 5px; vertical-align: top;"> <div style="border: 1px solid black; padding: 5px; margin-bottom: 5px;"> Feature Group 4 Selected Auto-Confirm </div> </td> <td style="width: 25%; padding: 5px; vertical-align: top;"> <div style="border: 1px solid black; padding: 5px; margin-bottom: 5px;"> LED 5-ON LED 1 & 2 Flashing </div> </td> <td style="width: 25%; padding: 5px; vertical-align: top;"> <div style="border: 1px solid black; padding: 5px; margin-bottom: 5px;"> Option 1 - Create Auto - Confirm </div> </td> <td style="width: 25%; padding: 5px; vertical-align: top;"> <div style="border: 1px solid black; padding: 5px; margin-bottom: 5px;"> LED 1 - ON All 5 LEDs Flashing </div> </td> <td style="width: 25%; padding: 5px; vertical-align: top;"> <div style="border: 1px solid black; padding: 5px; margin-bottom: 5px;"> Select Location 1-5 Read A New Super User Card </div> </td> <td style="width: 25%; padding: 5px; vertical-align: top;"> <div style="border: 1px solid black; padding: 5px; margin-bottom: 5px;"> Read Master Card 1 TIME Status LED ON System Back to Normal operation </div> </td> </tr> <tr> <td style="width: 25%; padding: 5px; vertical-align: top;"> <div style="border: 1px solid black; padding: 5px; margin-bottom: 5px;"> Auto-Confirm </div> </td> <td style="width: 25%; padding: 5px; vertical-align: top;"> <div style="border: 1px solid black; padding: 5px; margin-bottom: 5px;"> LED 5-ON LED 1 & 2 Flashing </div> </td> <td style="width: 25%; padding: 5px; vertical-align: top;"> <div style="border: 1px solid black; padding: 5px; margin-bottom: 5px;"> Option 2 - Delete Auto - Confirm </div> </td> <td style="width: 25%; padding: 5px; vertical-align: top;"> <div style="border: 1px solid black; padding: 5px; margin-bottom: 5px;"> LED 2 - ON All 5 LEDs Flashing </div> </td> <td style="width: 25%; padding: 5px; vertical-align: top;"> <div style="border: 1px solid black; padding: 5px; margin-bottom: 5px;"> Select Location 1-5 Auto - Confirm </div> </td> <td style="width: 25%; padding: 5px; vertical-align: top;"> <div style="border: 1px solid black; padding: 5px; margin-bottom: 5px;"> Location LED ON </div> </td> </tr> <tr> <td style="width: 25%; padding: 5px; vertical-align: top;"> <div style="border: 1px solid black; padding: 5px; margin-bottom: 5px;"> Auto-Confirm </div> </td> <td style="width: 25%; padding: 5px; vertical-align: top;"> <div style="border: 1px solid black; padding: 5px; margin-bottom: 5px;"> LED 5-ON LED 1 & 2 Flashing </div> </td> <td style="width: 25%; padding: 5px; vertical-align: top;"> <div style="border: 1px solid black; padding: 5px; margin-bottom: 5px;"> Option 2 - Delete Auto - Confirm </div> </td> <td style="width: 25%; padding: 5px; vertical-align: top;"> <div style="border: 1px solid black; padding: 5px; margin-bottom: 5px;"> LED 2 - ON All 5 LEDs Flashing </div> </td> <td style="width: 25%; padding: 5px; vertical-align: top;"> <div style="border: 1px solid black; padding: 5px; margin-bottom: 5px;"> Select Location 1-5 Auto - Confirm Execution with Bell Button </div> </td> <td style="width: 25%; padding: 5px; vertical-align: top;"> <div style="border: 1px solid black; padding: 5px; margin-bottom: 5px;"> Location LED ON </div> </td> </tr> </table>	<div style="border: 1px solid black; padding: 5px; margin-bottom: 5px;"> Feature Group 4 Selected Auto-Confirm </div>	<div style="border: 1px solid black; padding: 5px; margin-bottom: 5px;"> LED 5-ON LED 1 & 2 Flashing </div>	<div style="border: 1px solid black; padding: 5px; margin-bottom: 5px;"> Option 1 - Create Auto - Confirm </div>	<div style="border: 1px solid black; padding: 5px; margin-bottom: 5px;"> LED 1 - ON All 5 LEDs Flashing </div>	<div style="border: 1px solid black; padding: 5px; margin-bottom: 5px;"> Select Location 1-5 Read A New Super User Card </div>	<div style="border: 1px solid black; padding: 5px; margin-bottom: 5px;"> Read Master Card 1 TIME Status LED ON System Back to Normal operation </div>	<div style="border: 1px solid black; padding: 5px; margin-bottom: 5px;"> Auto-Confirm </div>	<div style="border: 1px solid black; padding: 5px; margin-bottom: 5px;"> LED 5-ON LED 1 & 2 Flashing </div>	<div style="border: 1px solid black; padding: 5px; margin-bottom: 5px;"> Option 2 - Delete Auto - Confirm </div>	<div style="border: 1px solid black; padding: 5px; margin-bottom: 5px;"> LED 2 - ON All 5 LEDs Flashing </div>	<div style="border: 1px solid black; padding: 5px; margin-bottom: 5px;"> Select Location 1-5 Auto - Confirm </div>	<div style="border: 1px solid black; padding: 5px; margin-bottom: 5px;"> Location LED ON </div>	<div style="border: 1px solid black; padding: 5px; margin-bottom: 5px;"> Auto-Confirm </div>	<div style="border: 1px solid black; padding: 5px; margin-bottom: 5px;"> LED 5-ON LED 1 & 2 Flashing </div>	<div style="border: 1px solid black; padding: 5px; margin-bottom: 5px;"> Option 2 - Delete Auto - Confirm </div>	<div style="border: 1px solid black; padding: 5px; margin-bottom: 5px;"> LED 2 - ON All 5 LEDs Flashing </div>	<div style="border: 1px solid black; padding: 5px; margin-bottom: 5px;"> Select Location 1-5 Auto - Confirm Execution with Bell Button </div>	<div style="border: 1px solid black; padding: 5px; margin-bottom: 5px;"> Location LED ON </div>
<div style="border: 1px solid black; padding: 5px; margin-bottom: 5px;"> Feature Group 4 Selected Auto-Confirm </div>	<div style="border: 1px solid black; padding: 5px; margin-bottom: 5px;"> LED 5-ON LED 1 & 2 Flashing </div>	<div style="border: 1px solid black; padding: 5px; margin-bottom: 5px;"> Option 1 - Create Auto - Confirm </div>	<div style="border: 1px solid black; padding: 5px; margin-bottom: 5px;"> LED 1 - ON All 5 LEDs Flashing </div>	<div style="border: 1px solid black; padding: 5px; margin-bottom: 5px;"> Select Location 1-5 Read A New Super User Card </div>	<div style="border: 1px solid black; padding: 5px; margin-bottom: 5px;"> Read Master Card 1 TIME Status LED ON System Back to Normal operation </div>														
<div style="border: 1px solid black; padding: 5px; margin-bottom: 5px;"> Auto-Confirm </div>	<div style="border: 1px solid black; padding: 5px; margin-bottom: 5px;"> LED 5-ON LED 1 & 2 Flashing </div>	<div style="border: 1px solid black; padding: 5px; margin-bottom: 5px;"> Option 2 - Delete Auto - Confirm </div>	<div style="border: 1px solid black; padding: 5px; margin-bottom: 5px;"> LED 2 - ON All 5 LEDs Flashing </div>	<div style="border: 1px solid black; padding: 5px; margin-bottom: 5px;"> Select Location 1-5 Auto - Confirm </div>	<div style="border: 1px solid black; padding: 5px; margin-bottom: 5px;"> Location LED ON </div>														
<div style="border: 1px solid black; padding: 5px; margin-bottom: 5px;"> Auto-Confirm </div>	<div style="border: 1px solid black; padding: 5px; margin-bottom: 5px;"> LED 5-ON LED 1 & 2 Flashing </div>	<div style="border: 1px solid black; padding: 5px; margin-bottom: 5px;"> Option 2 - Delete Auto - Confirm </div>	<div style="border: 1px solid black; padding: 5px; margin-bottom: 5px;"> LED 2 - ON All 5 LEDs Flashing </div>	<div style="border: 1px solid black; padding: 5px; margin-bottom: 5px;"> Select Location 1-5 Auto - Confirm Execution with Bell Button </div>	<div style="border: 1px solid black; padding: 5px; margin-bottom: 5px;"> Location LED ON </div>														
<p>NOTE: Auto - Confirm: The system confirms the feature / function automatically 2 seconds after selection.</p> <p>Audible Indications: 1 Beep - Selection; 2 Beeps - Confirm / Successful 1 Long Beep - Duplicated Card 5 Beeps - Fail</p>																			

APPLICATION EXAMPLES

1) Stand Alone Access Control Electric Lock

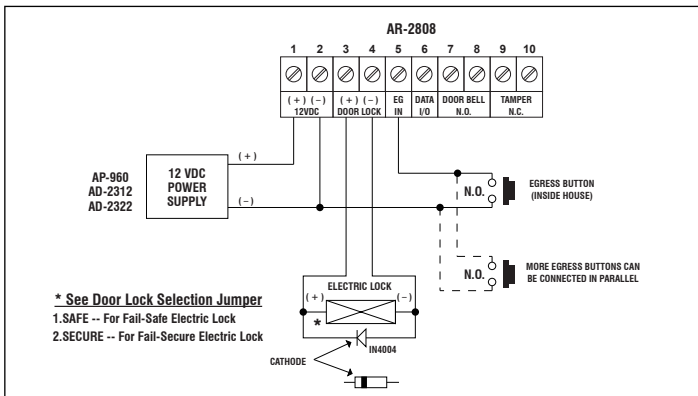

NOTE:

- Connect the 1N4004 as close as possible to the lock in parallel with the power terminals of the lock to absorb the back EMF to prevent it from damaging the reader. The 1N4004 is not required if the electric lock is AC operated.
- To avoid Electro-Static-Discharge from interfering with the operation of the reader, always ground the (-) terminal 2 to earth.

2) Application Hints for The Auxiliary Terminals

(A) TAMPER N.C.

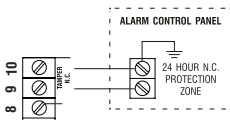

The tamper switch is Normally Closed while the reader is secured on box. It is open when the reader is removed from box. To give alert on sabotage, connect these terminals in series with a 24 hour N.C. protection zone of an alarm system if required.

(B) DOOR BELL N.O.

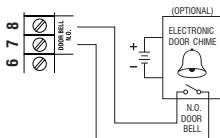

The connection of the Door Bell is optional. The door bell contact on the keypad is prepared for triggering of a low power door chime only. DO NOT use it as a high voltage power path for a door bell. The maximum power rating of the contact is 24V DC/1 Amp.

APPLICATION EXPANSION – The Optional Auxiliary Reader AR-2802

Apart from standard-alone operation, AR-2808 is expandable to be a Multi-station System with the optional auxiliary reader AR-2802. Maximum three optional readers can be allowed and the connection is very simple. Just connect the devices in parallel with the Data I/O Bus of the AR-2808. The AR-2808 acts as a server of the system and manages the data among them.

A Multi-station System provides higher security in access control and user convenience to operate an electric lock at different locations. Such as a dual reader system for area needs controlling of going in and going out with proximity EM cards.

The optional reader is available in standard version (AR-2802S) and advanced version (AR-2802A). The advanced version also provides Wiegand and RS-232 data outputs for custom project development with access control panel and / or PC.

The AR-2802 is also compatible with all the Tri-Tech keypads in the 2nd generation DK-2800 series for system expansion.

*** Please contact your local agent for the optional reader if system expansion is required.**

The Auxiliary Reader AR-2802 And It's Connection Terminals

Auxiliary Reader	Connection Terminals																				
	<table border="1" data-bbox="569 888 922 990"><tr><td>1</td><td>2</td><td>3</td><td>4</td><td>5</td><td>6</td><td>7</td><td>8</td><td>9</td><td>10</td></tr><tr><td></td><td></td><td></td><td></td><td></td><td></td><td></td><td></td><td></td><td></td></tr></table> <p data-bbox="787 1033 911 1055">AR-2802A ONLY</p>	1	2	3	4	5	6	7	8	9	10										
1	2	3	4	5	6	7	8	9	10												

Multi- Station Access Control Electric Lock

Description

The AR-2808 is expandable to a multi-station system for user convenience with the auxiliary reader AR-2802. Maximum 3 AR-2802 can be connected in parallel with the Data I/O Bus of the AR-2808. The auxiliary reader(s) reads the Cards as like the master reader AR-2808 which is the server of the system to manage the data from the auxiliary reader(s).

System Connection

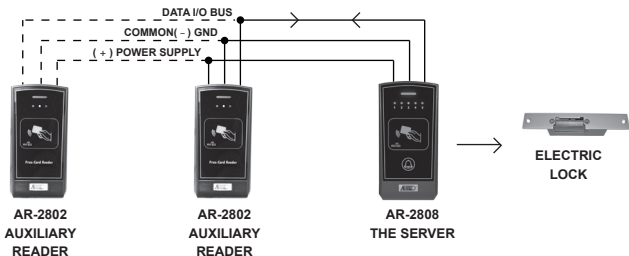

Wiring Diagram

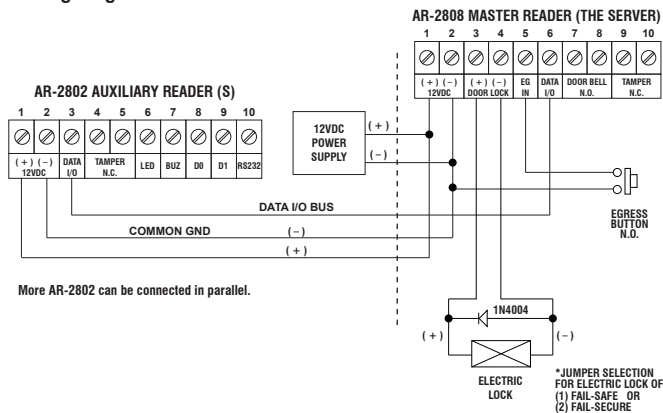

FCC STATEMENT

Caution:

Any changes or modifications not expressly approved by the party responsible for compliance could void the user's authority to operate this equipment.

This device complies with Part 15 of the FCC Rules. Operation is subject to the following two conditions:

(1) This device may not cause harmful interference, and

(2) this device must accept any interference received, including interference that may cause undesired operation.

This device and its antenna(s) must not be co-located or operating in conjunction with any other antenna or transmitter.

NOTE:

This equipment has been tested and found to comply with the limits for a Class B digital device, pursuant to Part 15 of the FCC Rules. These limits are designed to provide reasonable protection against harmful interference in a residential installation. This equipment generates, uses and can radiate radio frequency energy and, if not installed and used in accordance with the instructions, may cause harmful interference to radio communications. However, there is no guarantee that interference will not occur in a particular installation.

If this equipment does cause harmful interference to radio or television reception, which can be determined by turning the equipment off and on, the user is encouraged to try to correct the interference by one or more of the following measures:

- Reorient or relocate the receiving antenna.*
- Increase the separation between the equipment and receiver.*
- Connect the equipment into an outlet on a circuit different from that to which the receiver is connected.*
- Consult the dealer or an experienced radio/TV technician for help.*

