



JAG/RAV2

RES4601a
24 VOLT



**AUSTRALIAN STANDARDS APPROVED
REMOTE CONTROL ENGINE IMMOBILISER**



JAG: RES4601a AUSTRALIAN STANDARDS APPROVED IMMOBILISER.
RAV2: JAG PLUS BBSCV324V SIREN.

- This product complies with AS/NZS 3749.1 2003 Class A. Volumetric Sensing must be enabled to comply with a Class A installation (refer 'feature programming').
- Class A VSAS (Vehicle security alarm system) includes control equipment including setting and unsetting facilities, all sensors, warning devices and provisions for immobilization of the vehicle and the volumetric sensing device (glass break/shock).
- This product complies with AS/NZS 3749.1 2003 Class B. Volumetric Sensing must remain disabled to comply with a Class B installation (refer 'feature programming').
- Class B VSAS (Vehicle security alarm system) includes control equipment including setting and unsetting facilities, all sensors, warning devices and provisions for immobilization of the vehicle.
- This product complies with AS/NZS 4601:1999/Amdt 1: 2003
- This product is to be installed in accordance with the methods & principles detailed in AS 3749.2:1997

Has your insurer
specified fitting a
"RES2001"?
For details, please
refer to page 12



Instruction Manual Rev 5 29/07/2010

Thank you for purchasing a Rhino Engine Immobiliser. Please read this manual carefully before commencing installation and keep it in a safe place for future reference.

Contents

Contents	2
Features	3
Standard System Features	3
Selectable System Features (These features can be turned on and off)	3
Alarm System Features (Optional)	3
Optional Accessories	3
Detailed Feature Descriptions	4
Auto Immobilise	4
Automatic re-arm & relock (Programmable)	4
Door Ajar Warning (Programmable)	4
Timed Headlight Delay (Optional connection by installer at extra cost)	4
Perimeter Night Light (Programmable)	4
Dome Light Extension (Programmable)	4
Glass Break Sensor (For Optional Use Along with BBSCV324V Siren)	5
Door Lock On Ignition (Programmable)	5
Pre-Alert (2 Stage) Car Body Impact Warning with ETS™ (Only available when optional siren is fitted)	5
Auto Bypass	5
Operation	6
Remote Control Functions	6
Operation	6
Your Remote Control	6
Arming and Disarming Your Immobiliser	7
Activate Panic or Car Finder Function	7
Remote Boot Release	7
Programming Additional Remote Controls / Erasing Lost Remote Controls	7
Overriding the Immobiliser	8
Programming	8
How to Program the Selectable Features	8
How to Change REGISTER 1:	9
How to Change REGISTER 2:	11
Installation	12
“RES2001” Insurance Requirements	12
Installing the Main Control Unit	12
Internal Connector Diagram	12
Installing the BBSCV324V Siren	15
Connecting To An Existing Electric Boot Release Motor	15
Installing Optional Sirens	15
Installing Timed Headlight Delay	15
Connecting the Vehicle’s Door Switch to the Immobiliser	16
Connecting Your System To Central Locking	16
12V Connections	18
WARRANTY TERMS & CONDITIONS	19

Features

Standard System Features

- 24 Volt Operation
- Microprocessor Controlled
- Three Point Engine Immobilisation (Onboard Relays)
- Auto Immobilise (Passive Arming)
- Code Hopping Remote Technology (Anti-Scanning, Anti-Code Grabbing)
- Two SSR™ Solid State Remote Controls with 4 Function Operation (Arm / Disarm, Boot Release, Panic & LED Torch)
- Long Life Lithium Cell Remote Control Batteries (Each Remote Uses 2 x CR2025)
- Automatic Re-arm in case of Accidental Disarm
- Ultra-Bright Red Flashing LED Light
- Visual Arming and Disarming via Indicators (1 Flash For On, 2 Flashes For Off)
- Safety Circuit Prevents Arming While Ignition On
- Learning Mode for Adding Additional Remote Controls (maximum of 5)
- Negative On Alarm Output for Optional Internal Cabin Siren
- Onboard Central Locking Relay Outputs

Selectable System Features (These features can be turned on and off).

- Arm / disarm beeps (if optional siren fitted)
- Door ajar warning (indicators flash & siren (if fitted) beeps for 3 seconds if a door is left ajar i.e. Vehicle's interior light circuit sees door in open position)
- Electric boot release output via remote control – no delay (standard feature is to hold button for 3 seconds)
- Timed headlight delay (optional feature at additional installation cost)
- Multiple vehicle remote control (control 2 cars separately from the 1 remote)
- Central closure (allows electric window / sunroof closure on arming of some vehicles)
- Door lock on ignition (anti hi-jack)
- Perimeter night light (indicators hold on for 20 seconds on disarm)
- Dome Light Extension (interior light turns on for 20 seconds on disarm)
- User programmable override code in case of loss or damage of remotes (over 63,000 possible codes)
- Compatible with Wireless Keypad to allow arm/disarm of the system without remote controls.

Alarm System Features (Optional)

These features can be utilised once the optional BBSCV324V Model Back-up Battery Siren is fitted.

- All points of entry alarm protection (doors, boot, bonnet)
- Personal panic button via remote control (siren sounds & indicators flash)
- In-built 2 stage pre-alert car body impact sensor with ETS™
- Audio discriminating glass break sensor
- Alarm memory (allows recall of the 10 most recent alarm activations in order)
- Auto Bypass (prevents false alarms caused by faulty sensors / or switches)

Optional Accessories

- Backup Battery Siren (Standard on RAV2) (Part No: BBSCV324V)
- Internal Cabin Siren (Part No: DPS)
- Ultrasonic Sensors (Part No: UD6)
- Microwave Sensor (Part No: UD5)
- Electronic Tilt Sensor (Part No: TILTSENSE2)
- Paging System (Part No: APAGER)
- Wireless Keypad Upgrade (Part No: WKP)

Detailed Feature Descriptions

Auto Immobilize

The immobiliser will always automatically activate 38 seconds after the ignition is turned off no matter what. The dash mounted LED will come on constantly to confirm the system has entered auto immobilise mode. The vehicle cannot be started now unless the remote is pressed first. When disarming, if you do not switch the ignition on within 38 seconds, the immobiliser will also enter auto immobilise mode again. **Customers with central locking:** Make sure you watch the indicators flash once when you arm the system. You may wish to discuss with your installer fitting an optional siren (not expensive), so you can hear when you have locked your car. Otherwise, if you take longer than 38 seconds to exit your car & press the remote thinking you are locking it, in fact you will actually be just turning the immobiliser off temporarily & leaving your car unlocked. You must in this instance press your remote a second time to lock your vehicle.

Automatic re-arm & relock (Programmable)

This feature prevents accidental disarming by the owner i.e. the owner turns the immobiliser off but is then distracted and forgets that they have deactivated the system. If a door is not opened or ignition turned on within 60 seconds from when the system is turned off by the remote, the system will **fully re-arm & re-lock the vehicle**.

Note: The immobiliser will enter auto immobilise mode after 38 seconds (the LED will come on constantly to indicate the vehicle is immobilised). At the 60-second mark, the system will fully arm & the doors will lock – the blinkers will flash once & the siren (if fitted) will beep once & the LED will start flashing.

Door Ajar Warning (Programmable)

If the vehicles doors are not properly closed when you try to activate your immobiliser system, the indicators will flash for 3 seconds to alert you that the vehicle is not secure. If the optional BBSCV324V siren is fitted, it will also beep for 3 seconds.

Timed Headlight Delay (Optional connection by installer at extra cost)

You can have your car headlights turn on automatically for 15 seconds when you arm the immobiliser by remote control. This may allow you for instance to see your way to your front door, or out of a dark car park. You can turn the lights off before the 15-second period ends by pressing the left button on your remote.

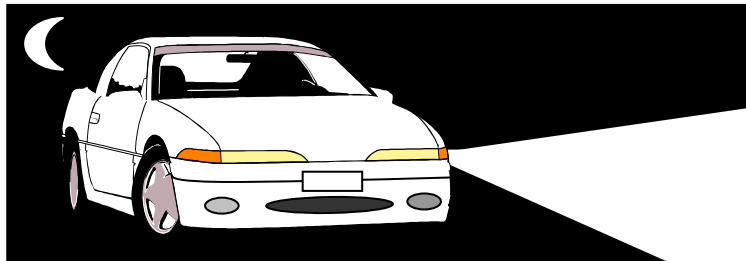

Perimeter Night Light (Programmable)

When this feature is on, the indicators will stay on constantly for 20 seconds on disarm, or until the ignition is turned on. This allows for illumination around the vehicle at night.

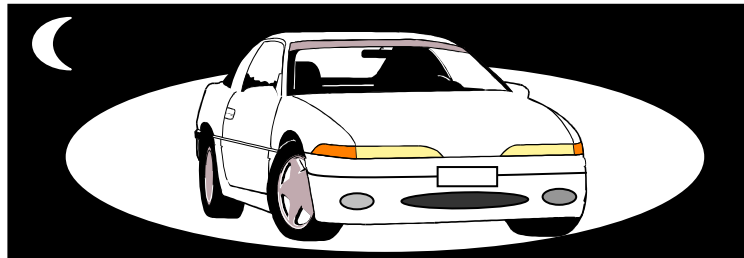

Dome Light Extension (Programmable)

The dome (interior) light comes on automatically when the system is disarmed via remote, enabling the owner to verify the vehicle is safe inside. The light stays on for 20 seconds, or until the ignition is turned on. The dome (interior) light also comes on automatically when the ignition is turned off, enabling the owner to quickly gather belongings before exiting the car. The light stays on for 20 seconds, or until the system is armed via remote, or until the ignition is turned on again. **NOTE:** If you activate the Automatic Rearm & Relock Feature, this feature will be disabled.

Glass Break Sensor (For Optional Use Along with BBSCV324V Siren)

The RES4601a with the addition of a special cabin microphone incorporates intelligent glass break sensing circuitry. This inbuilt device will trigger the alarm system, provided it registers the correct sound frequency parameters for breaking glass & that the impact sensor also registers a corresponding vibration to the vehicle. This ensures accurate detection of glass breakage.

Door Lock On Ignition (Programmable)

If you have central locking connected, when this feature is on the doors will lock when the ignition is turned to on, and unlock when the ignition is turned to off. This is to prevent anyone but occupants in the vehicle from being able to open the doors.

Pre-Alert (2 Stage) Car Body Impact Warning with ETS™ (Only available when optional siren is fitted)

This special feature provides a two-stage impact sensing system. It gives the security conscious owner a sensitive car body impact sensor that will give a potential thief prior warning that the vehicle is protected by this most formidable alarm system. On detection of a low level impact i.e. from a tyre kick, the siren will simply beep for a few seconds to warn away the would-be thief. If the vehicle is attacked any further, the system will move into full siren mode. The unique ETS™ Environment Tuned Sensor is able to distinguish between environmental shocks caused by aircraft, trucks, or extreme weather conditions, and the impact caused by any thief attempting to break in or other heavy impacts. Furthermore the system features the unique Rhino "Auto Adjust" process, where during the 20 sec. arming delay, the alarm samples the background noise where the vehicle is parked, and will if necessary automatically reduce the sensitivity of the impact sensor to an appropriate level. This process allows a trouble free sensitivity that ordinary alarms simply cannot provide. The sensitivity level reference point can be adjusted to suit your particular needs. Please refer to the programming section contained later in this manual.

Auto Bypass

Auto bypass is designed to reduce false alarms caused by faulty switches or external sensors. If the alarm is triggered 3 times by the same sector then the particular sector will be bypassed. (i.e. the sector will become inactive.) The sector will only be bypassed for one arming period. The next time the system is armed the sector that was bypassed will become active again.

Operation

Remote Control Functions

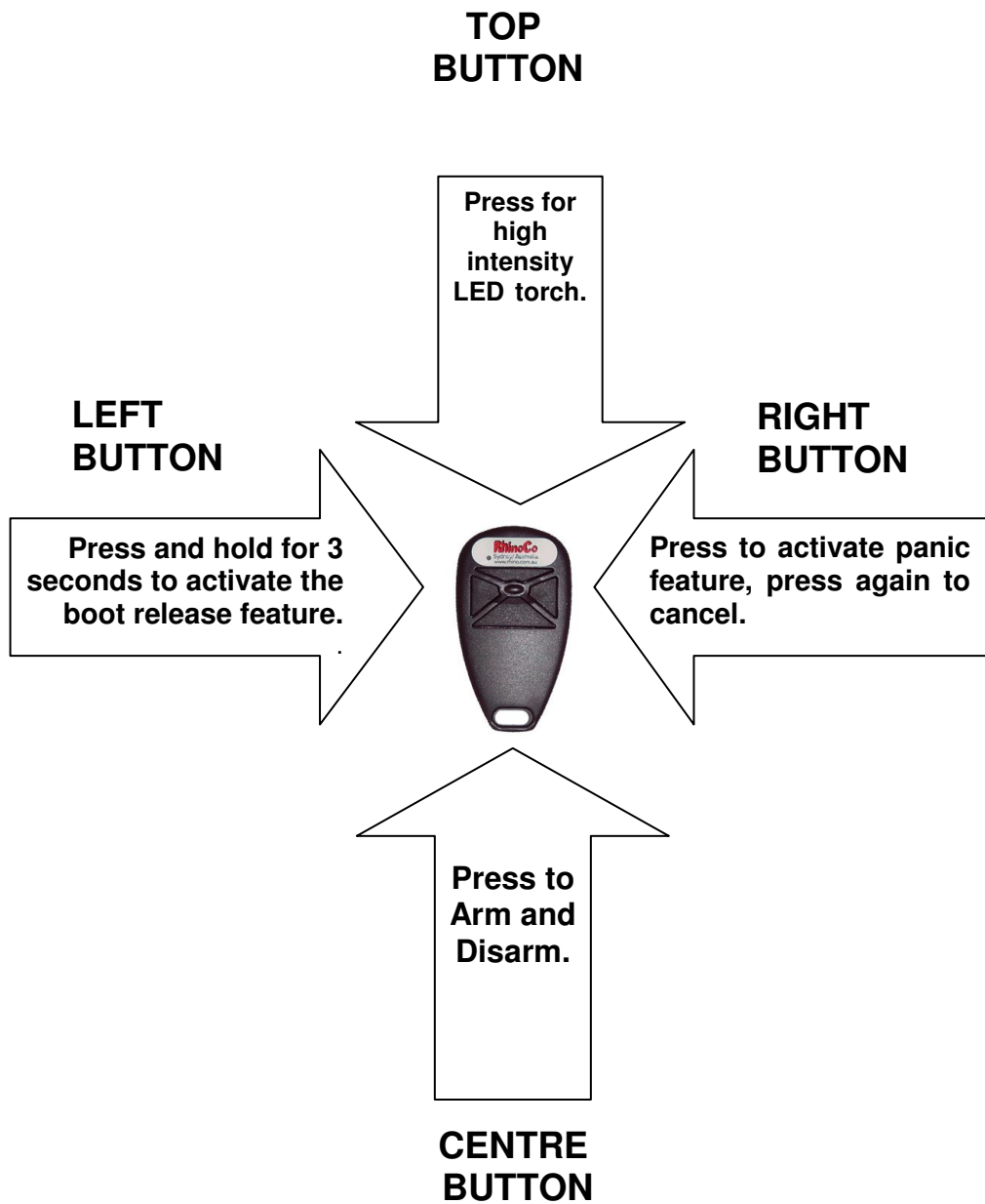

Arming and Disarming Your Immobiliser

TO ARM YOUR IMMOBILISER (& lock your vehicle if central locking is connected)

The immobiliser is activated by pressing the **Centre Button** on the remote control transmitter. The blinkers will flash once and (if fitted) the siren will beep once. For silent arm / disarm press both buttons (left and bottom) If central locking is connected, your doors will lock. The dash LED-light will stay on for 20 seconds then flash, **THE IMMOBILISER IS NOW ON.**



Press Centre Button

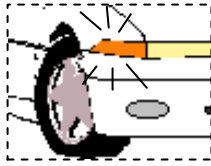

Blinkers will flash once

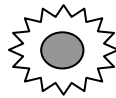

LED COMES ON.....and after 20 seconds starts to flash.

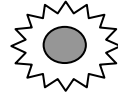
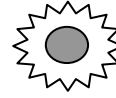

...

TO DISARM YOUR IMMOBILISER (& unlock your vehicle if central locking is connected)

To deactivate the immobiliser, press the **Centre Button**. The blinkers will flash twice and (if fitted) the siren will beep twice. The LED will stop flashing. If central locking is connected, your doors will unlock. **THE IMMOBILISER IS NOW OFF.** Note: If the alarm (optional) has been activated in your absence, the siren will beep 4 times on disarm.



Press Centre Button

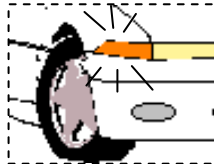

Blinkers will flash Twice

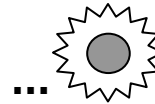

...

LED Switches OFF

EMERGENCY PANIC / CAR FINDER FUNCTION

The panic / car finder feature is activated by pressing the **Right Button** on the remote control transmitter. This causes the indicators to flash (i.e. same as hazard lights). If an optional siren is fitted, it will also sound. To cancel "panic", press the **Right Button** on the transmitter again. NOTE: Panic does not work when the ignition is on by requirement of Australian Law (EPA-Environmental Protection Agency).

Remote Boot Release

BOOT RELEASE (Optional connection by installer at extra cost)

This immobiliser is fitted with remote boot release capability for vehicles with existing electric boot release. This feature enables the user to unlock the boot by pressing the **Left Button** for **3 seconds**. The boot will unlock, and the immobiliser will disarm. NOTE: For safety reasons the remote boot release will not work when the ignition is on. **Note:** You can also program the boot to release as soon as you press the **Left**

Programming Additional Remote Controls / Erasing Lost Remote Controls

Your JAG (RES4601a) is supplied standard with 2 remote controls. You can use up to a maximum of 5. To add a new remote to your immobiliser, simply follow the procedure below:

1. Turn the vehicle's ignition to on.
2. Immediately press and hold the **Centre Button** on the original remote control until the indicators start to flash (approximately 4 seconds) and then release the button.
3. Immediately press and hold the **Centre Button** on the new remote control for at least 4 seconds.
4. Turn the vehicle's ignition off.
5. The new remote control is now programmed into the immobiliser.

Erasing Lost Remote Controls: If you lose a remote control or perhaps have your car keys stolen, you can simply erase the lost/stolen remotes by repeating the procedure above 6 times. This will fill the system memory with remotes that only you have in your possession.

Overriding the Immobiliser

PROCEDURE:

This feature enables the owner to override their immobiliser in case they have lost their remote controls or they have damaged them. You have the secure choice of over 63,000 possible codes. Refer to Register 2 of the Programmable Feature section of this manual (page 8) on how to choose your own code. **This should be done upon installation.**

To enter your override code:

1. Open your driver's door & leave it open. If you have an optional siren fitted, it will sound. This is normal.
2. Now turn the ignition from on to off an equal number of times to your first code digit (this is a number you have chosen between 3 and 255).
3. Wait for the blinkers to flash once. (This occurs whether you have entered the correct number or not).
4. Now turn the ignition from on to off an equal number of times to your second code digit (this is a number you have chosen between 3 and 255).
5. The immobiliser will now disarm. You must start your car within 38 seconds; otherwise the immobiliser will automatically rearm.
6. If you turn the ignition off, you will have to repeat this procedure every time you wish to start the car.

Programming

How to Program the Selectable Features

Your Rhino Security system incorporates the latest in high security & convenience features. It is possible to customise your security system so that it suits your requirements perfectly. Detailed below is the full list of programmable features that can either be turned on or turned off.

We have set, at the factory, the most common configuration chosen and these settings are listed in the REGISTER Settings listed below. Once the desired features have been selected, the selection is permanently retained in memory, even if power is removed.

To turn on or turn off any feature use the following procedure:

eg: to activate door lock on ignition.

1. Find the REGISTER (1or 2) in which the feature is located. (E.g. door lock on ignition is located in REGISTER 1).
2. Set the vehicle up as described to access REGISTER 1, (all doors closed, turning ignition on last).
3. After turning the ignition to on, immediately press the **Left Button** an equal number of times to the selected feature's **code** number (eg 3 times for door lock on ignition). Each press of the remote will be confirmed by a flash of the blinkers & the dash LED. If a siren is connected, it will give a confirmation beep.
4. Turn the ignition to off.
5. The system will then confirm which features are activated via visual readout. If a feature is enabled the LED & indicators will flash out its **code** corresponding to the number shown in the column "**Press Remote This Many Times**". The indicators in this example will flash once for arming beep on, then twice for disarm beep on, and then three times for door lock on ignition now being on.

How to Change REGISTER 1:

Vehicle Set Up: ALL DOORS CLOSED AND THE IGNITION TURNED ON LAST

Remote Key action: TURN ON / OFF FEATURES VIA THE LEFT BUTTON ON THE REMOTE

FEATURE	Press Remote This Many Times	FACTORY SETTING	DESCRIPTION
Arming Beep	1	ON	1 Beep on Arm (If optional siren fitted – contact your Rhino Dealer for more information).
Disarm Beep	2	ON	2 Beeps on Disarm (If siren fitted).
Door Lock on Ignition (Anti-Hijack)	3	OFF	When this feature is on, the doors will lock when the ignition is turned to on, and unlock when the ignition is turned to off.
No Door Ajar Warning	4	OFF	<u>When</u> this feature is <u>on</u> , the door ajar warning feature is removed (the siren – if fitted & indicators will <u>not</u> beep & flash for 3 sec. if a door is not closed properly).
Perimeter Night Light	5	OFF	When this feature is on, the indicators will stay on constantly for 20 seconds on disarm, or until the ignition is turned on. This allows for illumination around the vehicle at night.
Instant Boot Release	6	OFF	When this feature is on, the boot release button (Left Button) will only require be pressing once rather than holding down for 3 seconds to open an electric boot.
Negative on Alarm	7	OFF	When this feature is on, the –ARM wire changes to become “Negative On Alarm” instead.
Dome Light Extension (Interior lights on when ignition off, interior lights on when system disarmed via remote). Note: This feature cannot be turned on if Auto-Rearm & Relock is activated. See register 2.	8	OFF	The dome (interior) light comes on automatically when the system is disarmed via remote, enabling the owner to verify the vehicle is safe inside. The light stays on for 20 seconds, or until the ignition is turned on. The dome (interior) light also comes on automatically when the ignition is turned off, enabling the owner to quickly gather belongings before exiting the car. The light stays on for 20 seconds, or until the system is armed via remote, or until the ignition is turned on again.
Shock Sensor Adjustment	11	6 SELECT the level required.	After pressing the remote 11 times to enter this mode, turn the ignition to off. There are 8 levels of adjustment. The factory default setting is level 6. Pressing the remote once will increase the sensitivity by one level i.e. to level 7. The LED will then flash seven times to confirm the new level. Pressing the remote again will increase the sensitivity to level 8 (max). Pressing the remote again will return the adjustment to level 1 (least sensitive). Once you have adjusted the sensitivity level to the desired setting, turn the ignition on to exit this mode.
Installer Mode	12	SELECT The Mode Required	<u>After pressing the remote 12 times to enter this mode, turn the ignition to off.</u> This mode allows the installer / owner to verify that each trigger of the alarm system is working, without having to arm & disarm the system each time & set off the siren. The siren will beep and the blinkers will flash to indicate a trigger eg push the bonnet switch, open a door, hit the vehicle. The siren will beep four times to indicate a pre-warning impact sensor detection, or once to indicate full alarm trigger level. <u>Turn the ignition to on to exit this mode.</u>

PAT™ Past Alarm Trigger Memory	13	SELECT to replay memory	<p>After pressing the remote 13 times to enter this mode, turn the ignition off. Your Rhino Alarm offers a unique memory that stores the ten last reasons why the alarm was triggered. This memory cannot be erased.</p> <p>1 Beep, 1 Flash - Voltage Drop Alarm 2 Beep, 2 Flashes - Glass Break Alarm 3 Beep, 3 Flashes - Shock Sensor Alarm 4 Beep, 4 Flashes - Power Fail Alarm 5 Beep, 5 Flashes - Ignition Alarm 6 Beep, 6 Flashes - Aux Alarm 7 Beep, 7 Flashes - Door Alarms 8 Beep, 8 Flashes - Bonnet / Boot Alarm</p> <p>If two previous alarms were recorded i.e. Voltage drop and shock sensor the LED will flash and the siren will beep once for voltage drops, then no noise for 1 second then beep three times for shock sensor. The last memory heard is the most recent alarm sector triggered. Turn the ignition to on to exit this mode.</p>
Current Sense Override	15	ON	<p>When this feature is on, the alarm will not trigger when a sudden change in battery current is sensed.</p> <p>NOTE: This will ONLY beep out the state of this feature i.e. no other active features in the register will be beeped out. I.e. if this feature is NOT on, then NO beeps will be heard.</p>
Keypad Upgrade	18	OFF	<p>When this feature is turned on then the Wireless Keypad may be used to disarm the vehicle while still using the standard factory remotes to lock and unlock the vehicle. See the Wireless Keypad instructions for further details.</p> <p>If this featured is turned on then a single beep will be produced. If this feature is turned off then no beeps will be heard.</p>

How to Change REGISTER 2:

Vehicle Set Up: DRIVER'S DOOR OPEN, AND THE IGNITION TURNED ON LAST

Remote Key action: TURN ON / OFF FEATURES VIA THE LEFT BUTTON ON THE REMOTE

FEATURE	Press Remote This Many Times	FACTORY SETTING	DESCRIPTION
Centre button disabled.	1	OFF	Stop button centre button from arming and disarming, not normally used.
LEFT Button Used To Arm/Disarm This Vehicle	2	OFF	This is activated if you have two cars with Rhino remote controls, the vehicle that this is feature is activated on will use the left button to arm disarm and loose the ability to activate the boot release output.
Impact Sensor	3	ON	Activate 2 Stage Impact sensor & glass break sensor.
Automatic Rearm & Relock	4	OFF	This feature prevents accidental system disarming & will relock the doors if a door is not opened within 60 seconds. See page 2 for full function description. If you activate this feature, dome light extension will be turned off automatically. Installers must wire up the door circuit to function.
Timed Negative on Arm (Headlight Timer – 15 sec)	5	OFF	When on, this feature changes the –ARM wire from being a constant negative on arm to a timed 15 second negative on arm wire . This will allow you to connect this wire via a relay (see diagram on page 5) to your headlight circuit, so that when you arm your immobiliser, your headlights will turn on for 15 seconds to illuminate your path, and then automatically switch off. (You can press the LEFT button on your remote to turn the lights off before the 15-second period). You can still connect window lift modules to this wire, as long as it takes no longer than 15 seconds to wind up the windows in the car.
Selectable Indicator Flash	6	ON	When off, this feature prevents the indicators from flashing when the system is triggered.
Extended Lock Pulse (Central Closure)	7	OFF	When on, the lock output becomes a 15 second negative pulse instead of 0.5 seconds. This feature is for certain vehicles with vacuum central locking or those with a central closure wire (some BMW, Mercedes) i.e. doors lock, electric windows wind up, sunroof closes automatically.
Extended Unlock Pulse	8	OFF	When on, the unlock output becomes a 15 second negative pulse instead of 0.5 seconds. This feature is for certain vehicles with vacuum central locking.
Override Code	14	(3) (4)	This feature enables the owner to set their own individual code to override their immobiliser in case they have lost their remote controls or they are have stopped working. You have the secure choice of over 63,000 possible codes. To set a new code: <ol style="list-style-type: none"> 1. After pressing the remote 14 times to enter this mode, turn the ignition off. The blinkers will flash once to confirm you have entered the override code entry mode. 2. Now turn the ignition from on to off anywhere from 3 to 255 times i.e. 11 times 3. Wait for the blinkers to flash once. 4. Now turn the ignition from on to off anywhere from 3 to 255 times i.e. 36 times 5. Wait for the blinkers to flash once. 6. You have changed the override code from the factory setting of (3)(4) to (11)(36). 7. Make sure you remember the new override number! Do not record it anywhere where a would-be thief may find it in your car. <p>NOTE: The driver's door must be left open throughout this procedure.</p>

Installation

“RES2001” Insurance Requirements

Some Insurance Companies in Australia will now specify that they require a Rhino Model “RES2001” Immobiliser to be professionally fitted to their client’s vehicles before they will insure the vehicle for theft.

The code RES2001 has been especially given to insurance companies to make sure that their specified installation of a RES4601a is carried out to their client’s vehicles. If a customer says they need to have an RES2001 fitted this means that you must:

1. Be qualified to install an automotive security product, and if required hold the necessary security license (compulsory in NSW).
2. Install the Rhino JAG with 3 separate immobilisation points (i.e. starter, fuel, & ignition).
3. Provide your customer with an invoice stating that a “Rhino RES2001” has been installed.

Installing the Main Control Unit

Mount under the dash, in a well hidden location. Securely fix the main unit with cable ties or similar to prevent the unit from moving around. Failure to do this will result in poor shock sensor sensitivity, and may cause harm to the electronics.

Internal Connector Diagram

In case you loose track of a wire, expose the main harness connector by unclipping the case. Use the connector diagram below to trace your wire & its function.

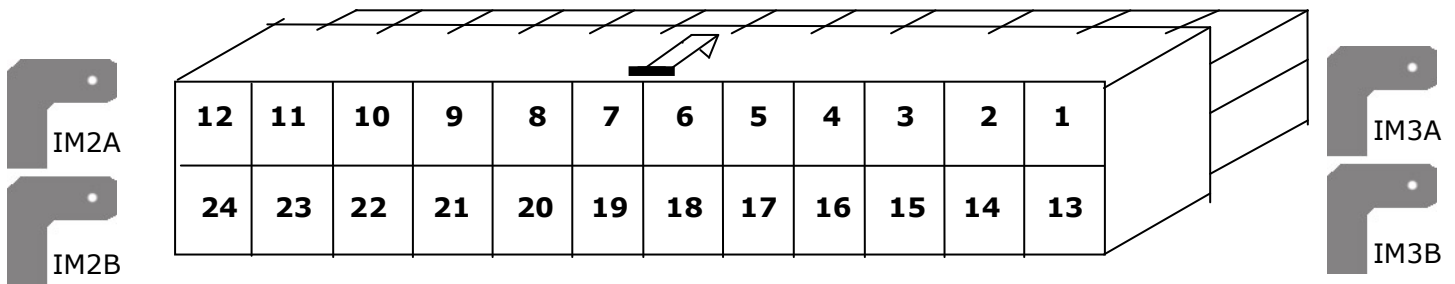

Pin	Connection	Pin	Connection
1	GND	13	IGN
2	Door	14	GND
3	IM1A	15	+ 24V
4	IM1A	16	Siren
5	IM1B	17	+ 24V
6	IM1B	18	- Arm
7	R - Blinker	19	Boot - Out
8	Lock NC	20	Hood
9	Lock COM	21	- LED
10	Lock NO	22	AUX
11	Unlock NC	23	L - Blinker
12	Unlock COM	24	Unlock NO

Important! Even though the connector plug for the JAG (RES4601a) is the same as the ones used in previous Rhino RES4601 and RA models, THEY ARE NOT COMPATIBLE.

Wire Number	CONNECTION
12	Unlock COM Refer to diagrams contained later in this manual for central locking connection
1 and 14 (2 Wires)	GND Connect to a suitable earth on the car body.
17, 15 & +LED (3 Wires)	24V Connect to constant +24 volts via the fuse box or from behind the ignition keybarrel. The negative side of the dash warning LED is already connected in the wiring harness, however the wire marked +LED must be connected to constant +24V.
16	Siren Connect this wire to the siren output wire from your siren. Note: You can only connect to specially coded Rhino sirens (BBSC24V). This output is not compatible with any other brand of siren as coded data is transmitted to turn the siren on and off.
18	-ARM “Negative on Arm Output” . When the system is armed, this wire outputs a negative (-ve 150MA). Connect to the trigger wire on optional Rhino GLU400 electric window lift module. Can also be programmed to become a “Timed Negative on Arm Output” When on, this feature changes the -ARM wire from being a constant negative on arm to a timed 15 second negative on arm wire . This will allow you to connect this wire via a relay (see diagram on page 4) to your headlight circuit, so that when you arm your immobiliser, your headlights will turn on for 15 seconds to illuminate your path, and then automatically switch off. (You can press the LEFT button on your remote to turn the lights off before the 15-second period). You can still connect window lift modules to this wire, as long as it takes no longer than 15 seconds to wind up the windows in the car. “Negative on alarm” output must be taken from the BBSC24V siren.
19	BOOT - OUT This is the negative output for boot release (150 mA maximum). Optional for use where electric boot release is to be connected. 40A Changeover Relay required. See connection diagram for detail.
20	HOOD Connect to Bonnet switch
21	-LED This wire is already connected from the wiring harness to the positive side of the dash LED.
22	AUX This is a “Negative Trigger Input” , and can be connected to the output circuit wire on any optional alarm accessory to be used. i.e. ultrasonic or microwave sensors.
7 and 23	Blinker Connect to the left and right indicator (blinker) circuits of the vehicle to flash the indicators. Each circuit can supply a maximum 4A
24	Unlock NO Refer to diagrams contained later in this manual for central locking connection
2	-DOOR Connect to existing door switch circuit. (Please note: only negative switching doors, if positive door switching - must use relays to reverse to negative - see diagram contained later in this manual)
IM1A 3 & 4 (2 Wires) & IM1B 5 & 6 (2 Wires)	Immobilisation Circuits. The starter wire is usually located under the steering column of the vehicle. This wire must be +24 Volts only when the vehicle is being started. Cut this wire. The vehicle should not start. Solder the starter motor side to both wires marked IM1B. Solder the other end to both wires marked IM1A. Repeat the above configuration for the electric fuel pump with wires IM2A & IM2B.
IM2A (2 Wires) & IM2B (2 Wires)	Repeat the above configuration for your third immobilisation circuit with wires IM3A & IM3B.
IM3A (2 Wires) & IM3B (2 Wires)	NOTE: For safety purposes, under no circumstances should you cut the vehicle’s main ignition system. To confirm that you haven’t cut the ignition wire: while the system is armed, make sure that your dash warning lights still come on (illuminate) when you turn the ignition to the ON position.
8	Lock NC Refer to diagrams contained later in this manual for central locking connection
9	Lock COM Refer to diagrams contained later in this manual for central locking connection
10	Lock NO Refer to diagrams contained later in this manual for central locking connection
11	Unlock NC Refer to diagrams contained later in this manual for central locking connection
13	IGN Connect to a +24 volts ignition switched lead , which does not fall to 0 volt when the engine is cranked.

Antenna Wire:
For best operating range, keep vertical & straight. Leave in free space (do not tie up with any wiring harness, or put right next to metal).

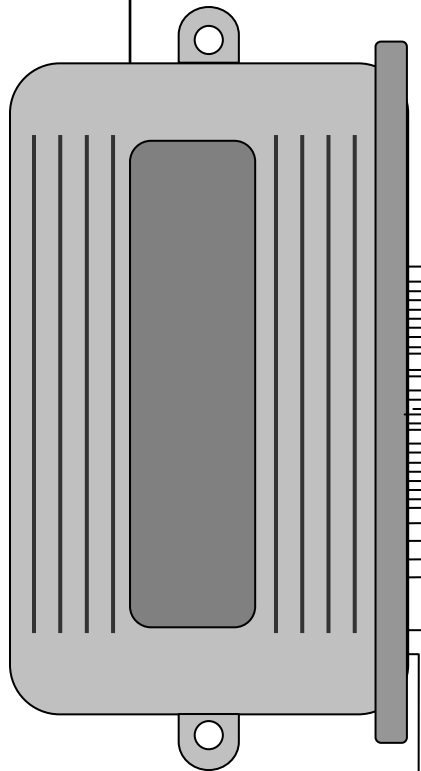

24V: Connect to constant +24VDC

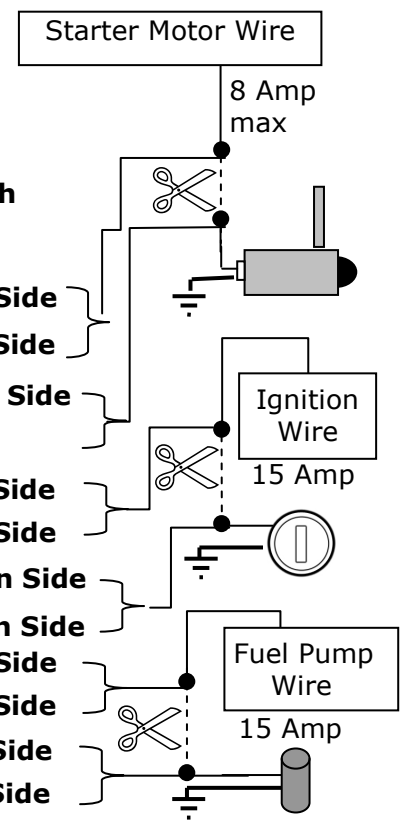
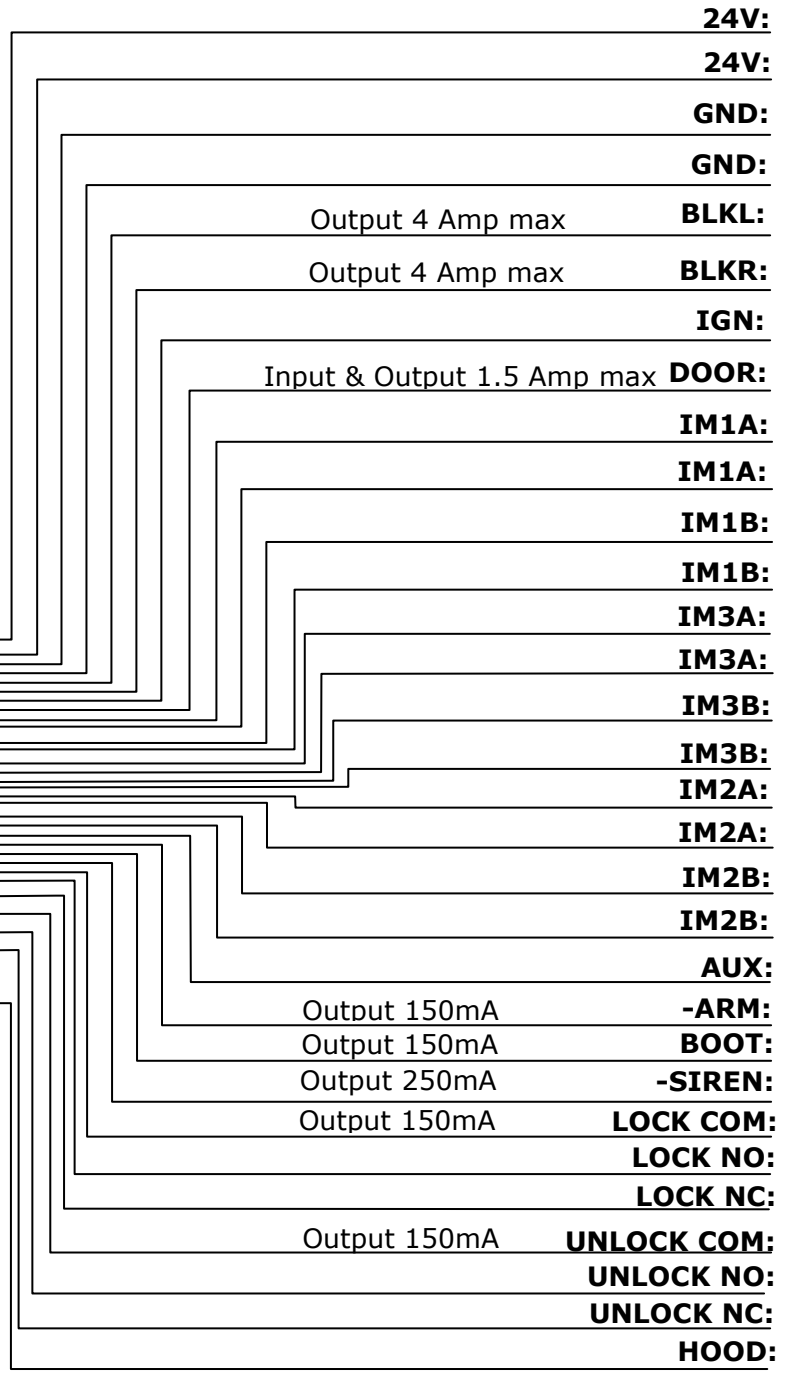
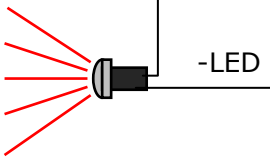

Installing the BBSCV324V Siren

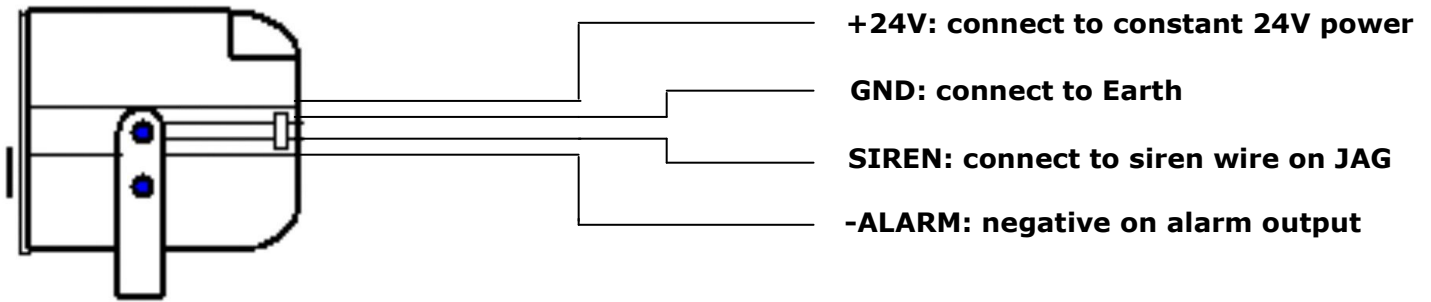

Connecting To An Existing Electric Boot Release Motor

Note: A 24Volt 40 Amp Changeover Relay is required.

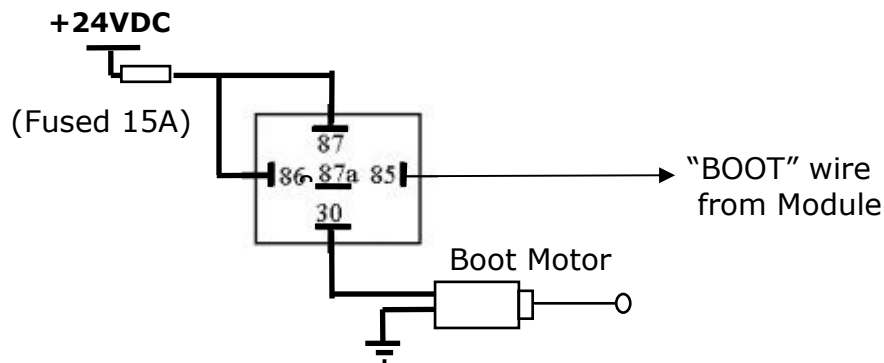

Installing Optional Sirens

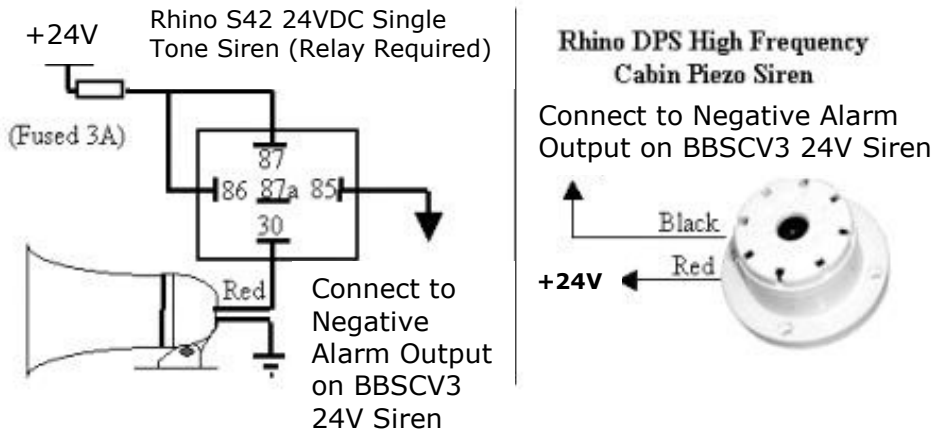

Installing Timed Headlight Delay

Note: A 40 Amp Changeover Relay is required.

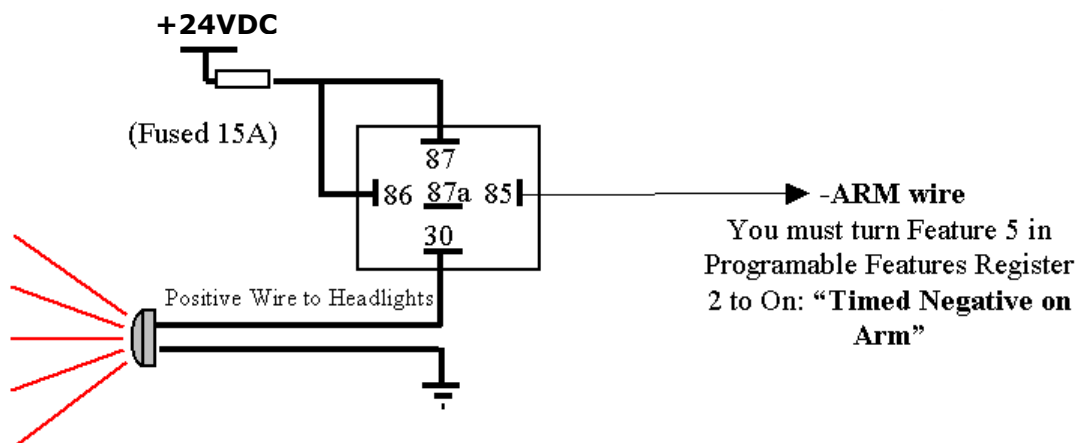

Connecting the Vehicle's Door Switch to the Immobiliser

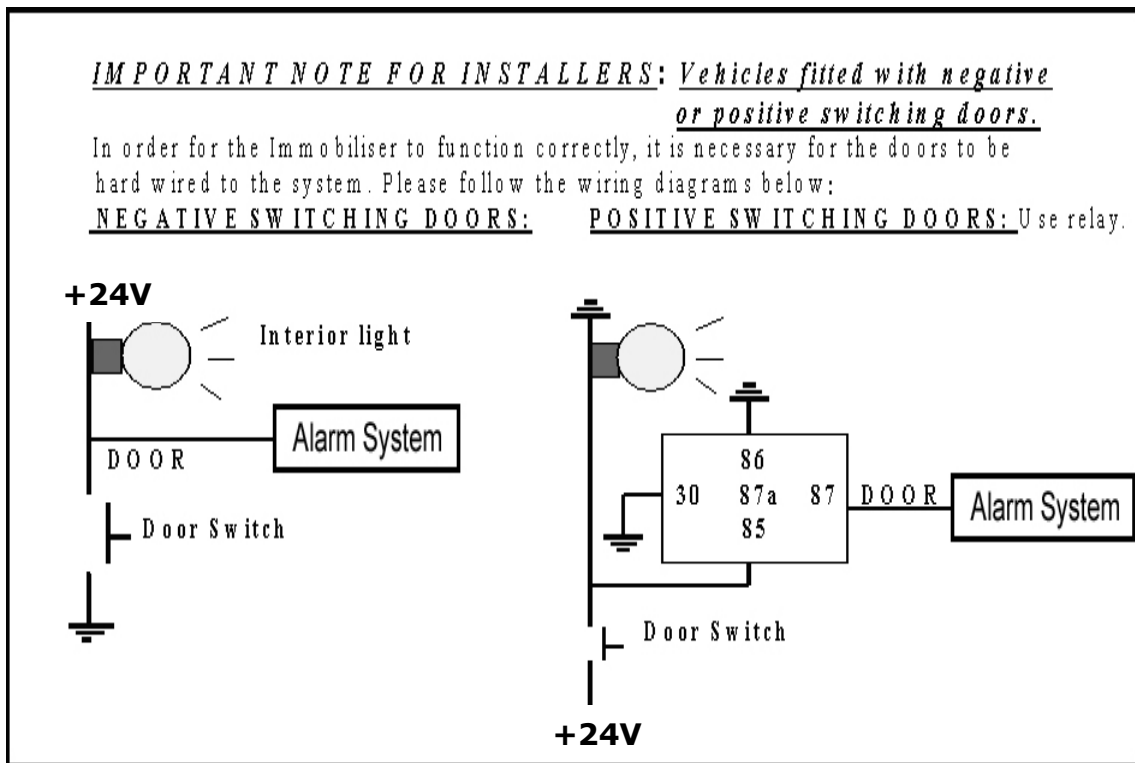

Connecting Your System To Central Locking

Connecting to Negative Pulse Central Locking Systems:

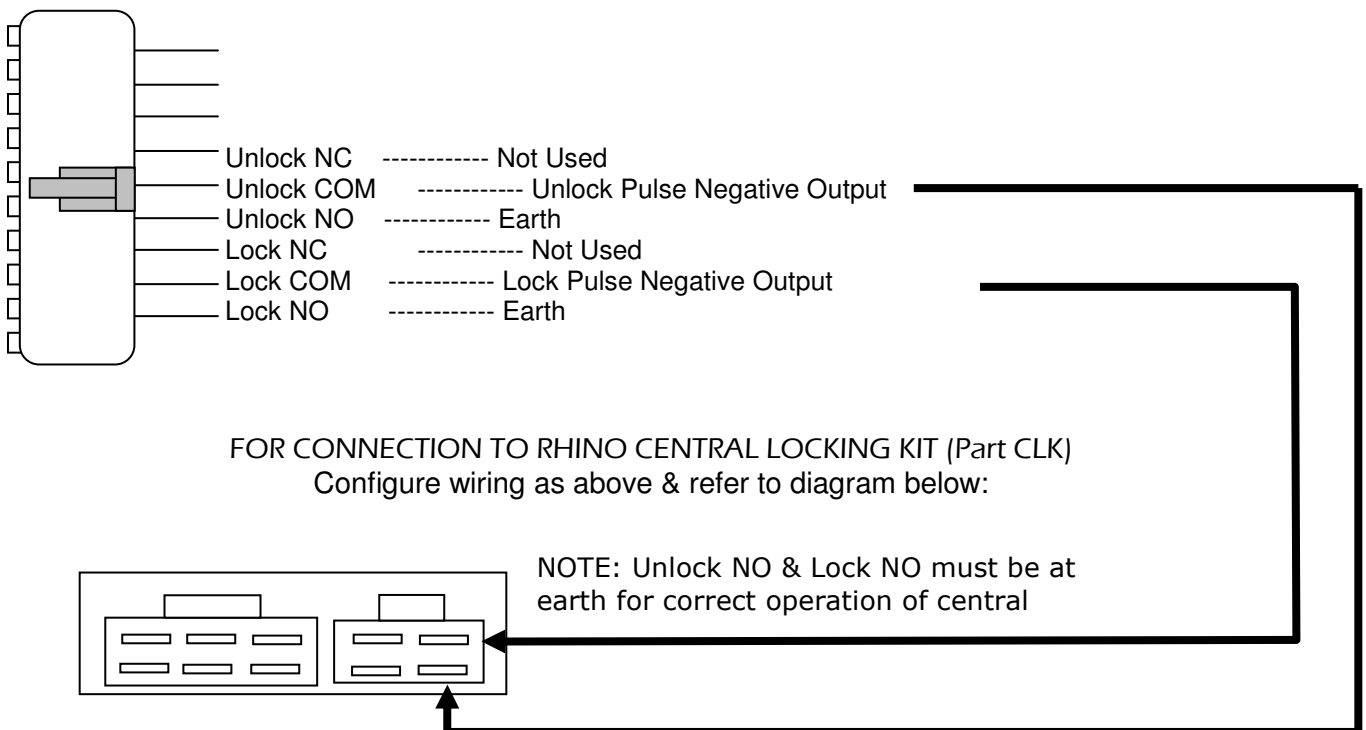

Connecting to a New Door Motor

Installing a new single central locking motor is often required in vehicles that have factory locking but have no motor in the driver's door, or where you would like "keyless entry" on just the driver's door.

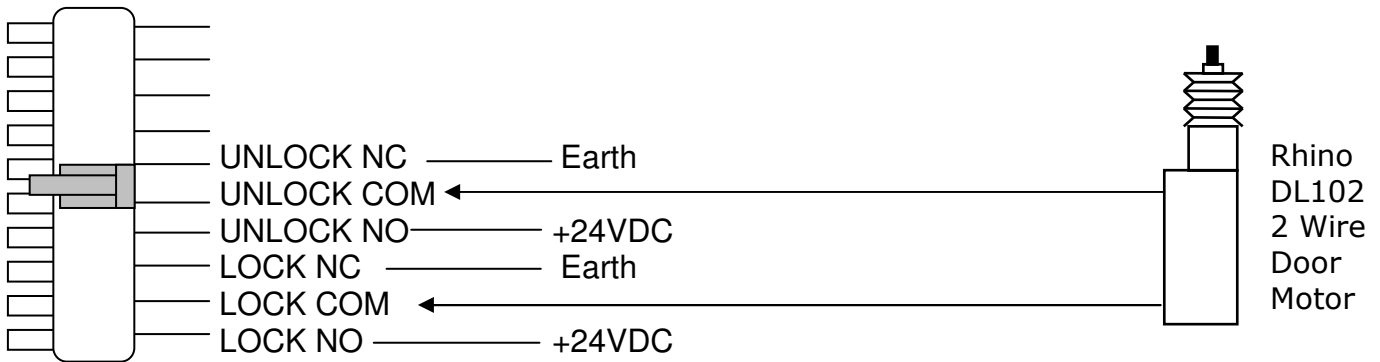

Connecting to Negative or Positive Activated Central Locking Systems

- **FOR POSITIVE AT REST THEN GOING NEGATIVE:** Connect UNLOCK NO & LOCK NO to Earth
- **FOR NEGATIVE AT REST THEN GOING POSITIVE:** Connect UNLOCK NO & LOCK NO to 24VDC

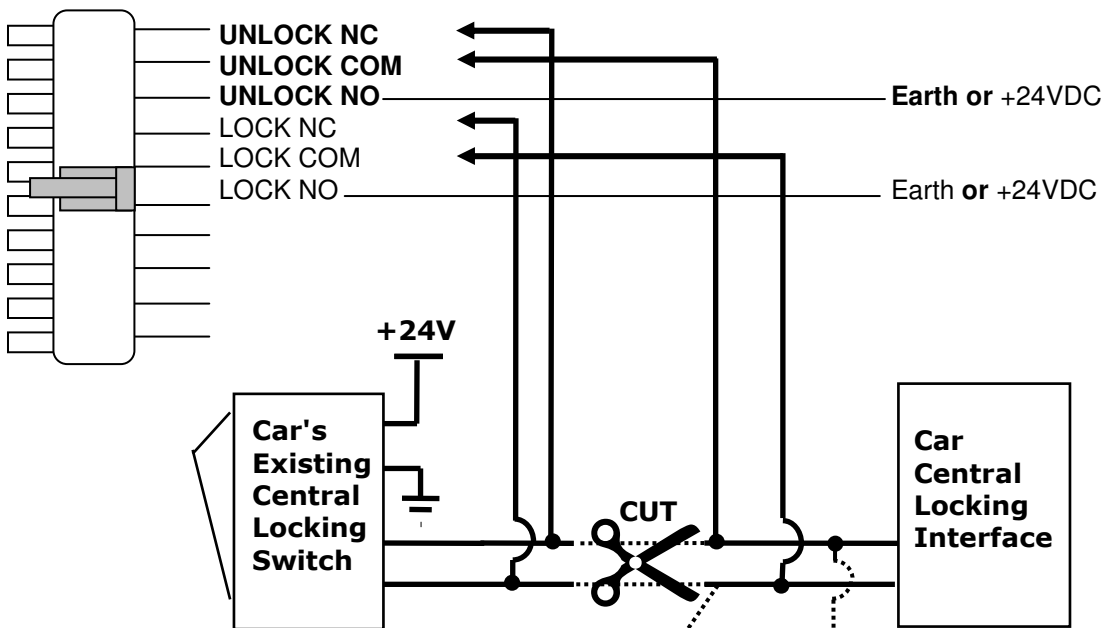

For Floating Switches: Neither +24V or Earth at Rest
Connect 2 additional relays as shown below & connect Red/Blue & Black Green to +24VDC

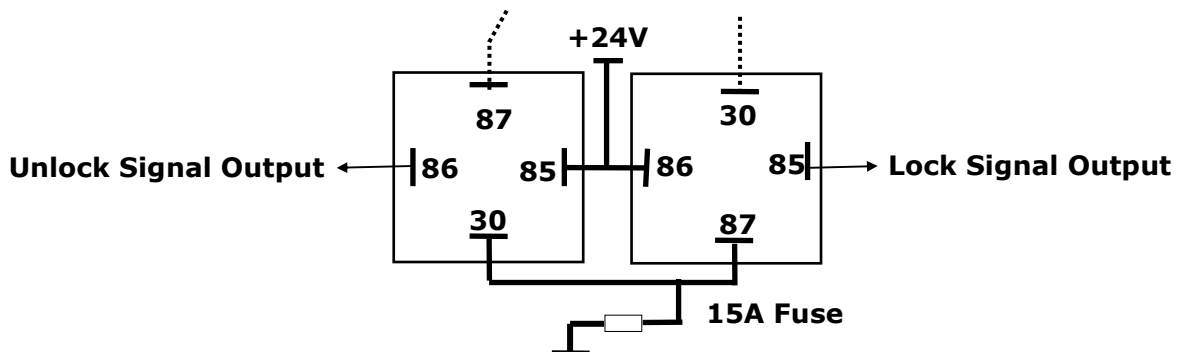

Connection For Two Stage Unlocking Using Rhino Central Locking Kit

Pressing centre button unlocks driver's door only. Pressing left button for 3 seconds unlocks all doors.

Pressing centre button again locks all doors. (Like VT Commodore operation).

Note: When installing our Central Locking Kit, fit only a DL102 slave (2 wire) motor in the drivers door. Interrupt the unlock wire of the motor with wires as shown.

Note: Lock NO must be connected to earth & Unlock NO must be connected to 12V for correct operation.

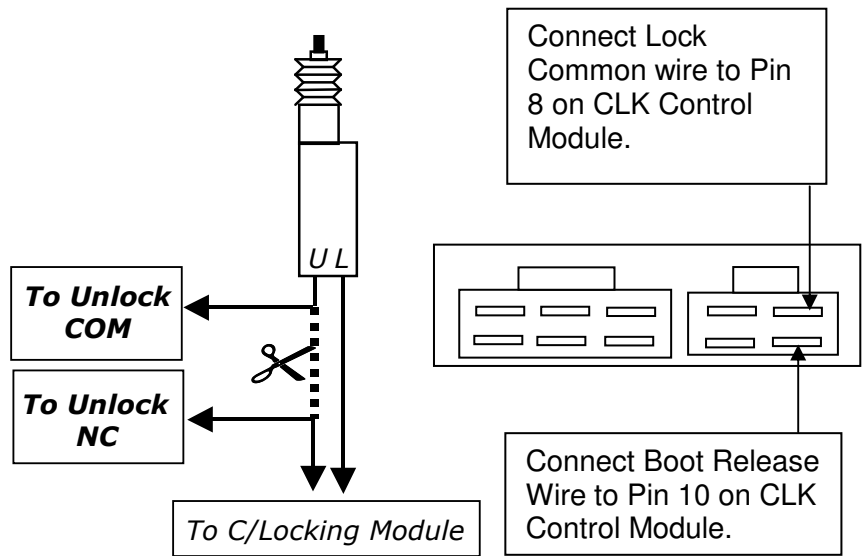

12V Connections

12V connections must be made as shown in the figure below. All 24V vehicles have 2 12V batteries. 12V can be simply taken from in between these batteries.

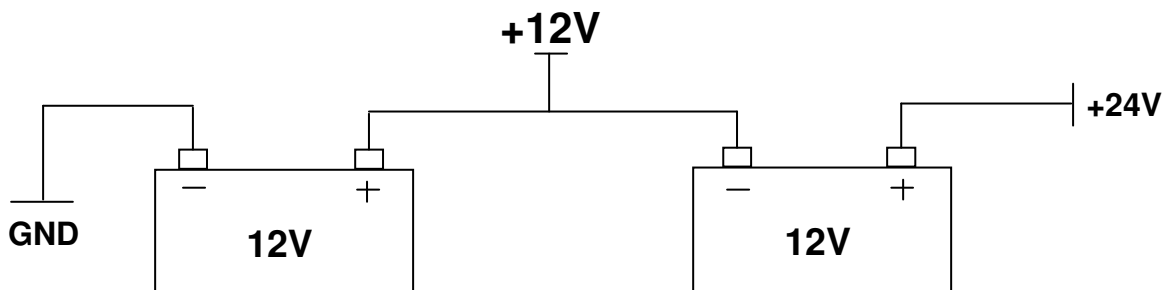

WARRANTY TERMS & CONDITIONS

RhinoCo Technology (The Company) warrants its products to be in conformance with its own plans and specifications and to be free from defects in materials and workmanship under normal use and service for 12 months from the date stamp control on the product, or for products not having a date stamp, for twelve months from the date of original purchase unless the installation instructions or catalogue sets forth a shorter period, in which case the shorter period shall apply. The Company's obligation shall be limited to repairing or replacing, at its option, free of charge for materials or labor, any part which is proved not in compliance with The Company's specifications or proves defective in materials or workmanship under normal use and service. The Company shall have no obligation under this Limited Warranty or otherwise if the product is altered or improperly repaired or serviced by anyone other than The Company.

For warranty service, return transportation prepaid, to RhinoCo Technology, 9 Hannabus Place McGraths Hill NSW 2756 Australia.

There are no warranties, expressed or implied, of merchant ability, or fitness for a particular purpose or otherwise, which extend beyond the description on the face hereof. In no case shall The Company be liable to anyone for any consequential or incidental damages for breach of this or any other warranty, express or implied, or upon any other basis of liability whatsoever, even the loss or damage is caused by its own negligence or fault.

The Company does not represent that the products it sells may not be compromised or circumvented; that the products will prevent any personal injury or property loss by burglary, robbery, fire or otherwise; or that the products will in all cases provide adequate warning or protection. Customer understands that a properly installed and maintained alarm system may only reduce the risk of a burglary, robbery, or fire without warning, but it is not insurance or a guarantee that such will not occur or that there will be no personal injury or property loss as a result.

Consequently, The Company shall have no liability for any personal injury; property damage or other loss based on a claim the product failed to give any warning. However, if The Company is held liable, whether directly or indirectly, for any loss or damage arising under this limited warranty or otherwise, regard less of cause or origin, The Company's maximum liability shall not in any case exceed the purchase price of the product, which shall be the complete and exclusive remedy against The Company.

This warranty replaces any previous warranties and is the only warranty made by The Company on this product. No increase or alteration, written or verbal, of the obligations of this Limited Warranty is authorised.

